



Eko-Okna S.A. is a global Polish manufacturer of premium joinery, specializing in PVC, timber, aluminium, and steel. While high-performance windows and doors form the core of our constantly expanding portfolio, our range is complemented by sliding systems, solar shading, sectional garage doors, perimeter fencing, insect screens, and pergolas.

Eko-Okna is renowned for its ability to engineer solutions tailored to specific markets and to meet the most unique requirements of individual customers. Our products reach nearly 40 export markets, including the EU, the USA, Australia, and African countries.

A key advantage of Eko-Okna is our proprietary transport fleet: trucks equipped with on-board forklifts, allowing for immediate unloading at the customer's site. Exports to the USA are handled via regular container shipments.

Eko-Okna partners can rely on comprehensive sales support from multilingual advisors and gain access to constantly evolving online solutions – the eko4u sales tool and the Benefit Eko-Okna educational platform.

ALUPROF SYSTEMS



MB-45	8
MB-60	9
MB-79N	10
MB-79N CASEMENT	11
MB-86N	12
MB-104 PASSIVE	13
MB-FERROLINE	14
MB-SLIDE	15
MB-59 HS	16
MB-77 HS	17
MB-86 FOLD LINE HD	18
MB-60E EI	19
MB-78 EI	20
MB-86 EI	21
EXTENSION PROFILES	22



MB-45

WINDOW AND DOOR SYSTEM



Constructions based on the MB-45 system are a perfect complement to office buildings. It allows for the effortless creation of even the most complex solutions such as swing doors and arched windows (fixed glazing only).

TECHNICAL DATA	MB-45
Frame depth	45 mm
Sash depth (door/window)	45 mm / 54 mm
Glazing thickness (doors and fixed windows / opening windows)	2 – 25 mm / 2 – 34 mm
MINIMUM VISIBLE PROFILE WIDTH	
Frame (door/window)	66,5 mm / 43,5 mm
Sash (door/window)	72 mm / 27,5 mm
MAXIMUM DIMENSIONS AND WEIGHTS OF THE STRUCTURE	
Max. window dimensions	H 2400 mm L 1250 mm
Max. door sash dimensions	H 2400 mm L 1250 mm
Max. sash weight (door/window)	120 / 130 kg

MB-60

WINDOW AND DOOR SYSTEM



Using the MB-60 system, we can produce turn, tilt, tilt-and-turn, and tilt-and-slide windows, as well as doors. One of the most interesting product variants is the MB-60 PIVOT, which enables the creation of pivot windows.

TECHNICAL DATA	MB-60 / HI	MB-60US / HI	MB-60 PIVOT
Frame depth	60 mm		
Sash depth (door/window)	60 mm / 69 mm	69 mm	
Glazing thickness (doors and fixed windows / opening windows)	5 – 41 mm 14 – 50 mm	4 – 35 mm 8 – 44 mm	5 – 41 mm 14 – 50 mm
MINIMUM VISIBLE PROFILE WIDTH FROM THE OUTSIDE			
Frame (door/window)	51 mm / 47 mm	75 mm	47 mm
Sash (door/window)	72 mm / 29 mm	34,6 mm	76 mm
MAXIMUM DIMENSIONS AND WEIGHTS OF THE STRUCTURE			
Max. window dimensions	H 2400 mm L 1250 mm	H 1900 mm L 1100 mm	H 2000 mm L 2400 mm
Max. door dimensions	H 2400 mm L 1200 mm		
Sash weight (door/window)	120 kg / 130 kg	130 kg	180 kg

MB-79N

WINDOW AND DOOR SYSTEM



MB-79N SI



MB-79N E



MB-79N ST



OPTION
GLASS CORNER

The MB-79N system is an economical window and door solution that meets enhanced standards for thermal and acoustic insulation. It is used to produce various types of fenestration, such as fixed, turn, tilt, and tilt-and-slide windows, single and double-leaf external doors, and shopfronts with doors.

TECHNICAL DATA	MB-79N ST / MB-79N SI / MB-79N E
Frame depth	70 mm
Sash depth	79 mm
Glazing thickness	1,5 - 63 mm
MINIMUM VISIBLE PROFILE WIDTH FROM THE OUTSIDE	
Frame/wall frame	50,5 mm
Sash/wall sash	33,5 mm
MAXIMUM DIMENSIONS AND WEIGHTS OF THE STRUCTURE	
Max. door sash dimensions	H 2700 mm L 1700 mm
Max. sash weight	180 kg

MB-79N CASEMENT

WINDOW SYSTEM



The MB-79N CASEMENT is a window system with enhanced thermal and acoustic insulation and high weather tightness. It allows for the creation fixed, side hung and top hung windows.

TECHNICAL DATA	MB-79N TOP HUNG / MB-79N SIDE HUNG
Frame depth	70 mm
Sash depth	79 mm
Glazing thickness	frame: 1,5 - 54 mm sash: 10,5 - 63 mm
MAXIMUM DIMENSIONS AND WEIGHTS OF THE STRUCTURE	
Max. sash dimensions	H 2700 / 2500 mm L 1400 / 2400 mm
Max. sash weight	180 kg

MB-86 CASEMENT

WINDOW SYSTEM



The MB-86 Casement system features additional insulating elements as standard, enabling it to achieve excellent thermal performance in all conditions. Combined with high air-tightness, this delivers outstanding thermal comfort without having to compromise on the sleek, modern design of slim aluminium or significantly increasing the investment cost.

TECHNICAL DATA	MB-86 CASEMENT
Frame depth	77 mm
Sash depth	86 mm
Glazing thickness	frame: 14 - 60 mm sash: 18 - 60 mm
MAXIMUM DIMENSIONS AND WEIGHTS OF THE STRUCTURE	
Max. sash dimensions	H 2300 mm L 1400 mm
Max. sash weight	100 kg

MB-86N

WINDOW AND DOOR SYSTEM



The MB-86N system belongs to a group of products with excellent thermal insulation. It can be customized with, among other things, a double-sided handle, external fixed glazing (FIX), and a nailing fin for the American market.

TECHNICAL DATA	MB-86N
Frame depth (window/door)	77 mm / 77 mm
Sash depth (window/door)	86 mm / 77 mm
Glazing thickness	frame: 8,5 - 61 mm sash: 17,5 - 70 mm
MAXIMUM DIMENSIONS AND WEIGHTS OF THE STRUCTURE	
Max. sash dimensions	window H 2800 mm L 1700 mm door H 3000 mm L 1400 mm
Max. sash weight	150 kg / 200 kg

MB-104 PASSIVE

WINDOW SYSTEM



Windows made with the MB-104 Passive system meet the highest requirements for thermal insulation, confirmed by certificates from the Passive House Institute (PHI) in Darmstadt. The system combines technical capabilities, excellent thermal protection, and aesthetics.

TECHNICAL DATA	MB-104 PASSIVE
Frame depth	95 mm
Sash depth	104 mm
Glazing thickness	frame: 27 - 72 mm sash: 34,5 - 81 mm
MAXIMUM DIMENSIONS AND WEIGHTS OF THE STRUCTURE	
Max. sash dimensions	H 2900 mm L 1700 mm
Max. sash weight	160 kg

MB-FERROLINE

WINDOW SYSTEM



MB-FERROLINE
INDUSTRIAL

The Ferroline system is primarily recommended for the renovation of historic buildings. It can be used to create all types of inward-opening windows (turn, tilt, tilt-and-turn), outward-opening windows, and fixed windows, which, in addition to excellent thermal insulation, also feature very good acoustic insulation and water and air tightness.

TECHNICAL DATA	MB-FERROLINE
Frame depth	110 mm
Sash depth	86 mm – 93,5 mm
Glazing thickness	13,5 mm – 61,5 mm
MAXIMUM DIMENSIONS AND WEIGHTS OF THE STRUCTURE	
Max. sash dimensions	H 2400 mm L 1400 mm
Max. sash weight	150 kg

MB-SLIDE

SLIDING DOOR SYSTEM



The MB-Slide system offers vast construction possibilities, thereby enhancing spatial design. It is available in various configurations, from two to six sashes.

TECHNICAL DATA	MB-SLIDE
Frame depth (2 tracks/3 tracks)	50 mm / 97 mm
Sash depth	37 mm
Glazing thickness (fix/opening sash)	24 mm
MINIMUM VISIBLE PROFILE WIDTH	
Frame	44,5 mm
Sash	68,5 mm
MAXIMUM DIMENSIONS AND WEIGHTS OF THE STRUCTURE	
Max. sash dimensions	H 2600 mm L 1800 mm
Max. sash weight	160 kg

MB-59 HS

LIFT-AND-SLIDE DOOR SYSTEM HST



The MB-59HS system allows for the creation of structures consisting of up to six sashes. This enables you to create a stunning connection between the interior and the natural environment, as well as a convenient exit to a terrace, balcony, or open garden space.

TECHNICAL DATA	MB-59HS ST / MB-59HS HI
Frame depth	120 mm (2-track profile), 199 mm (3-track profile)
Sash depth	59 mm
Glazing thickness	up to 42 mm
MINIMUM VISIBLE PROFILE WIDTH FROM THE OUTSIDE	
Frame	44 mm
Sash	83,5 – 94,5 mm
MAXIMUM DIMENSIONS AND WEIGHTS OF THE STRUCTURE	
Max. sash dimensions	H 2800 mm L 3000 mm
Max. sash weight	300 kg

MB-77 HS

LIFT-AND-SLIDE DOOR SYSTEM HST

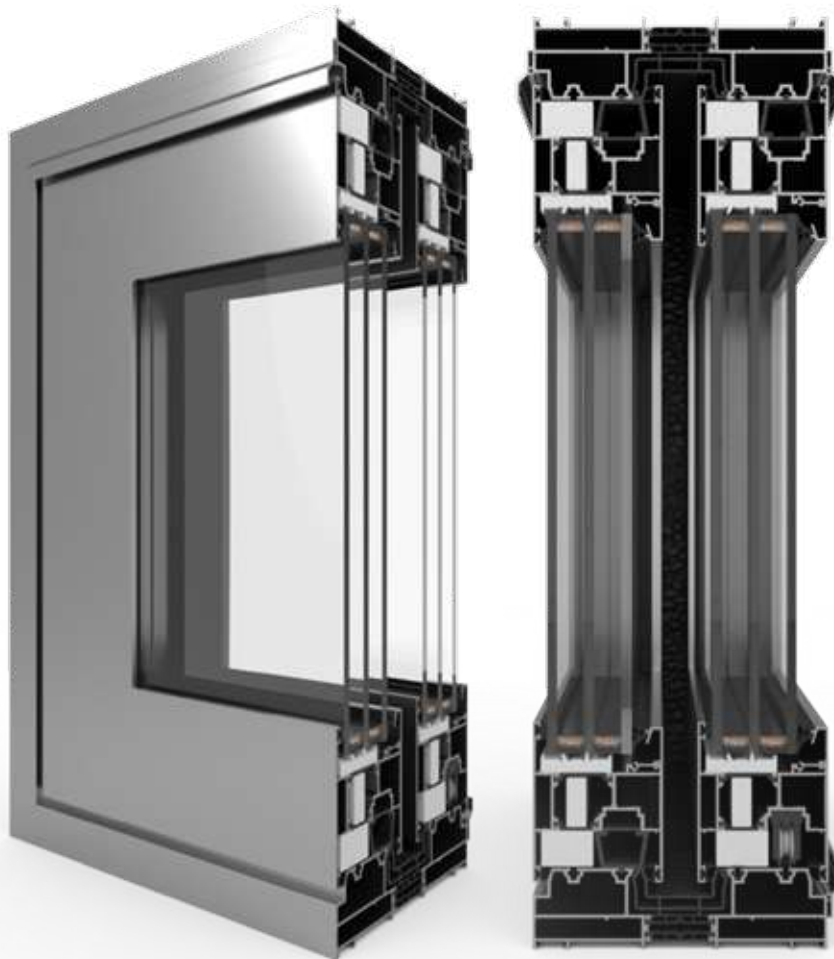

MB-77 HS
MONRAIL

OPTION
GLASSCORNER

The system allows for the creation of a glazed or opening corner, the use of a narrow mullion, and the inclusion of an additional insulator (HI version).

TECHNICAL DATA	MB-77 HS / MB-77 HI
Frame depth	174 mm / 271 mm
Sash depth	77 mm
Glazing thickness	13,5 – 58,5 mm
MINIMUM VISIBLE PROFILE WIDTH FROM THE OUTSIDE	
Frame	48 mm
Sash	94,5 – 105,5 mm
MAXIMUM DIMENSIONS AND WEIGHTS OF THE STRUCTURE	
Max. sash dimensions	H 3200 mm L 3200 mm
Max. sash weight	400 kg

MB-86 FOLD LINE HD

FOLDING DOOR SYSTEM



MB-86 FOLD LINE HD allows creation of large external folding doors that can open/fold both outwards and inwards. The partition can be configured based on many different schemes. This system offers the widest range of threshold solutions, including those with rebate sealing and convenient, concealed thresholds.

TECHNICAL DATA	MB-86 FOLD LINE HD
Frame depth	77 mm
Sash depth	77 mm
Glazing thickness	up to 60 mm
MAXIMUM DIMENSIONS AND WEIGHTS OF THE STRUCTURE	
Max. sash dimensions	H 3000 mm L 1000 mm
Max. sash weight	120 kg

MB-60E EI

FIRE-RATED SYSTEM*

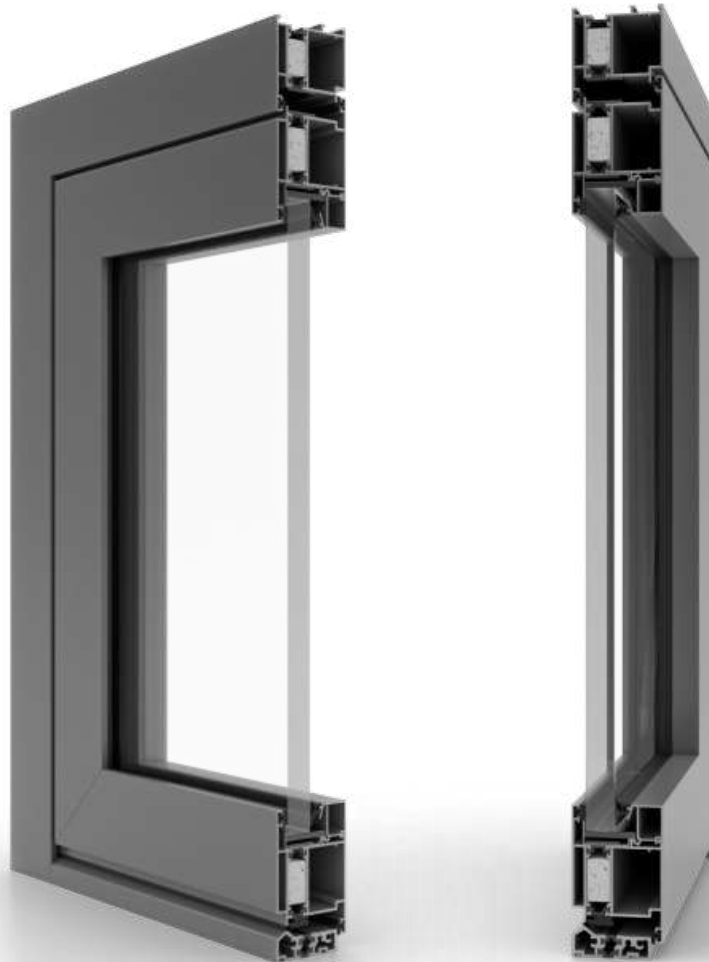

MB-60E EI solutions boast a fire resistance class of EI 15 or EI 30 in accordance with the PN-EN 1350-2+A1:2010 standard. They use 60 mm thick aluminium profiles with a thermal break and fire insulation in the chambers.

TECHNICAL DATA	MB-60E EI
Frame depth	60 mm
Sash depth	60 mm
Glazing thickness	5 – 41 mm
MINIMUM VISIBLE PROFILE WIDTH FROM THE OUTSIDE	
Door frame/wall frame	62,5 mm / 55 mm
Door sash/wall transom	67 mm / 76 mm
MAXIMUM DIMENSIONS AND WEIGHTS OF THE STRUCTURE	
Max. sash dimensions	L 1400 mm H 2475 mm
Max. sash weight (door / window)	120 kg

*availability of specific solutions depends on the market

MB-78 EI

FIRE-RATED SYSTEM*



The MB-78 EI system is used for constructing internal or external fire partitions with single and double-sash doors, with a fire resistance class from EI 30 to EI 60, according to the PN-EN 13501-2:2010 standard.

TECHNICAL DATA	MB-78 EI
Frame depth (mullions)	78 mm
Sash depth (transoms)	78 mm
Glazing thickness	6 – 49 mm
MINIMUM VISIBLE PROFILE WIDTH FROM THE OUTSIDE	
Door frame/wall frame	51 / 72 mm
Door sash/wall transom	72 / 51 mm
MAXIMUM DIMENSIONS AND WEIGHTS OF THE STRUCTURE	
Max. sash dimensions	H 2500 mm L 1400 mm
Max. sash weight	250 kg

*availability of specific solutions depends on the market

MB-86 EI

FIRE-RATED* WINDOW SYSTEM



The MB-86 EI system is designed for creating external fire-rated partitions. It can be used to construct windows with an EI 30 fire resistance class according to the PN-EN 13501-2:2016 standard, which means they will provide an effective barrier against the spread of fire for at least 30 minutes.

TECHNICAL DATA	MB-86 EI
Frame depth	77 mm
Sash depth	86 mm
Glazing thickness	up to 70 mm
MAXIMUM DIMENSIONS AND WEIGHTS OF THE STRUCTURE	
Max. sash dimensions	H 2500 mm L 1400 mm
Max. sash weight (door / window)	160 kg

*availability of specific solutions depends on the market

MB-118 EI

FIRE-RATED SYSTEM*



MB-118EI aluminium partition walls are a modern fire-rated solution that can function as both internal and external partitions. The structure is fully compatible with the MB-78EI system. Fire resistance class EI 120.

TECHNICAL DATA	MB-118 EI
Installation depth	118 mm
Infill width	31 - 84 mm
MAXIMUM DIMENSIONS AND WEIGHTS OF THE STRUCTURE	
Max. sash dimensions	H 3000 mm L 1500 mm
Max. sash weight (door / window)	410 kg

*availability of specific solutions depends on the market

EXTENSION PROFILES

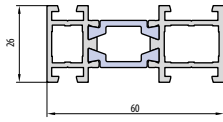

K518467

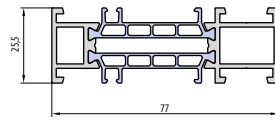

K528600

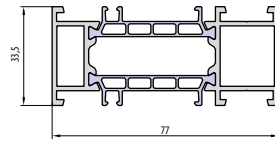

K528601

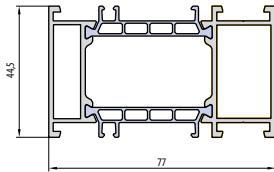

K528602

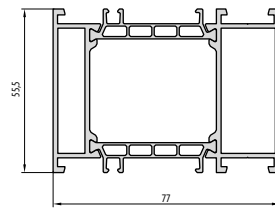

K528603

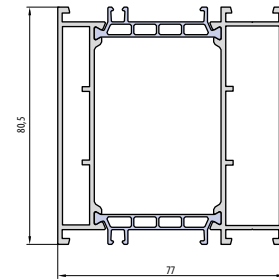

K528643

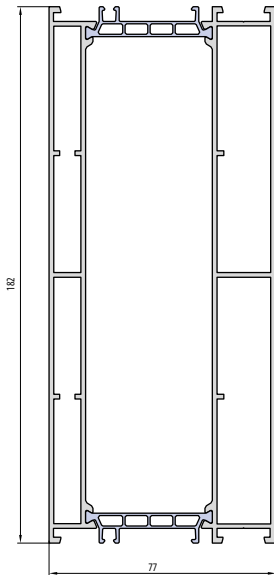

K528668

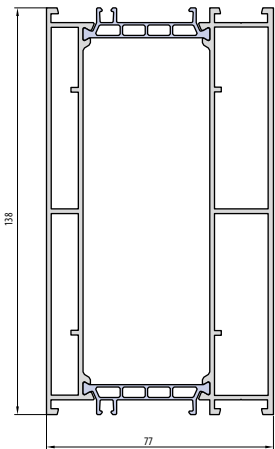

K528664

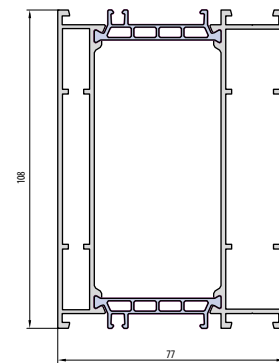

K528669

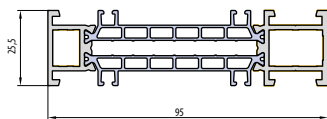

K519000

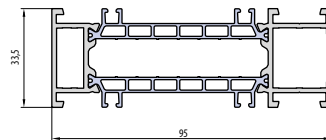

K519001

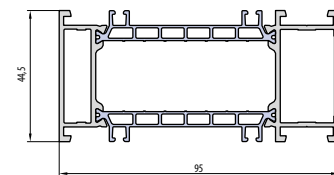

K519002

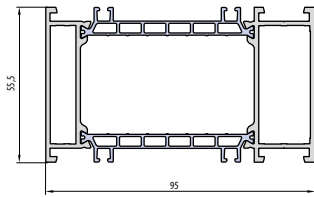

K519003

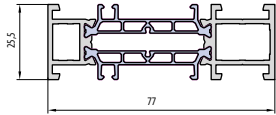

K518600

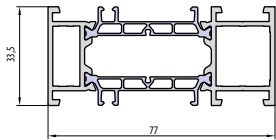

K518601

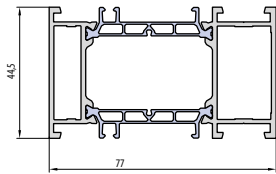

K518602

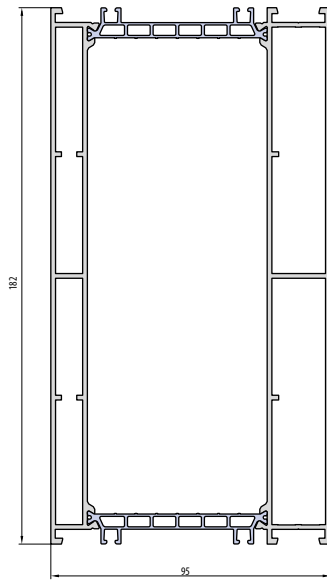

K519068

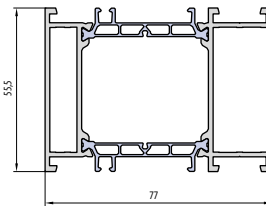

K518603

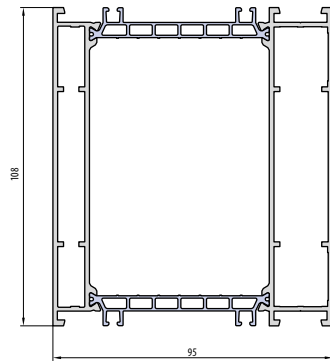

K519069

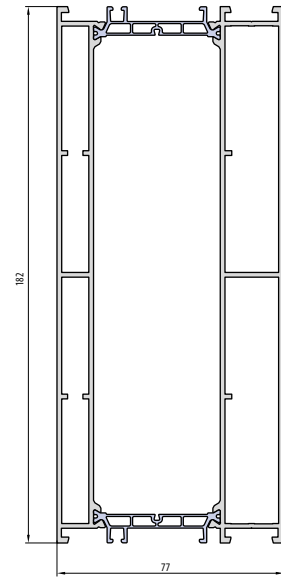

K519069

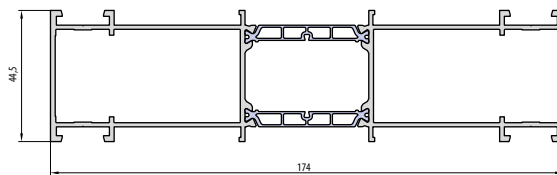

K518894

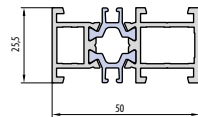

K518339

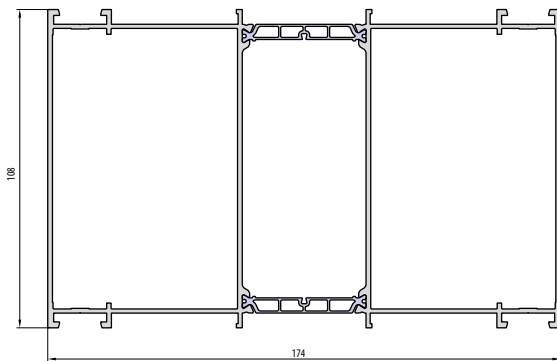

K518897

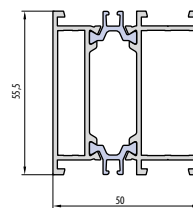

K518341

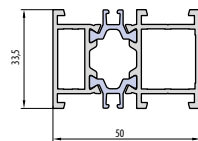

K518340

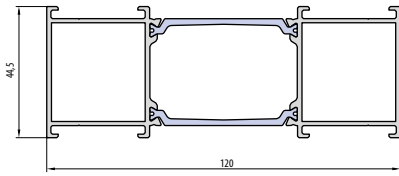

K530046

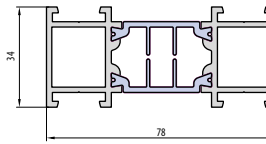

K518142

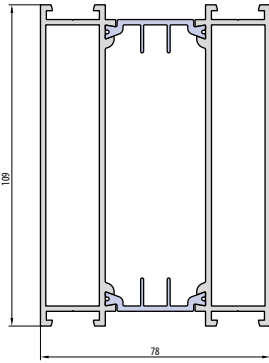

K518145

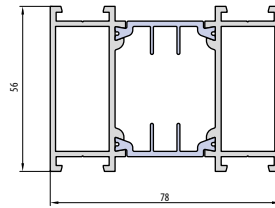

K518143

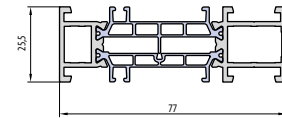

K718600

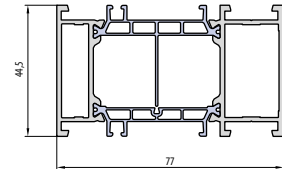

K718602

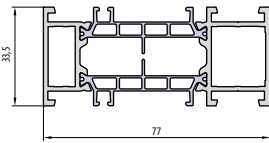

K718601

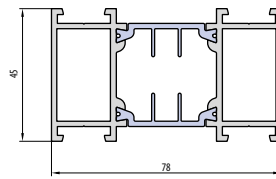

K518149

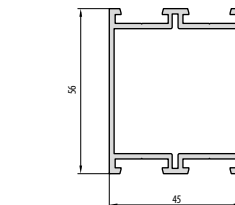

K417898

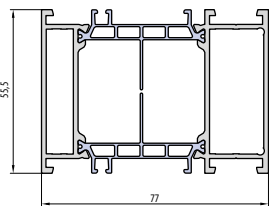

K718603

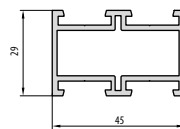

K417897

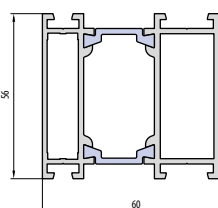

K518294

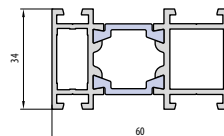

K518298

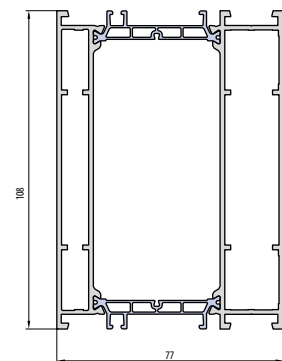

K518669



ALIPLAST SYSTEMS

aliplast®

ECONOLINE	30
ECOFUTURAL	31
ECOFUTURAL OC 65	32
IMPERIAL	33
GENESIS	34
SUPERIAL	35
MAXLIGHT	36
VS 600	37
SLIDE GLASS	38
MODERNSLIDE	39
VISOGLIDE	40
VISOGLIDE PLUS	41
ULTRAGLIDE	42
ULTRAGLIDE MAXLIGHT MONORAIL	43
PANORAMA	44
FR 65 EI	45
FR 90 EI	46
EXTENSION PROFILES	48



ECONOLINE

WINDOW AND DOOR SYSTEM

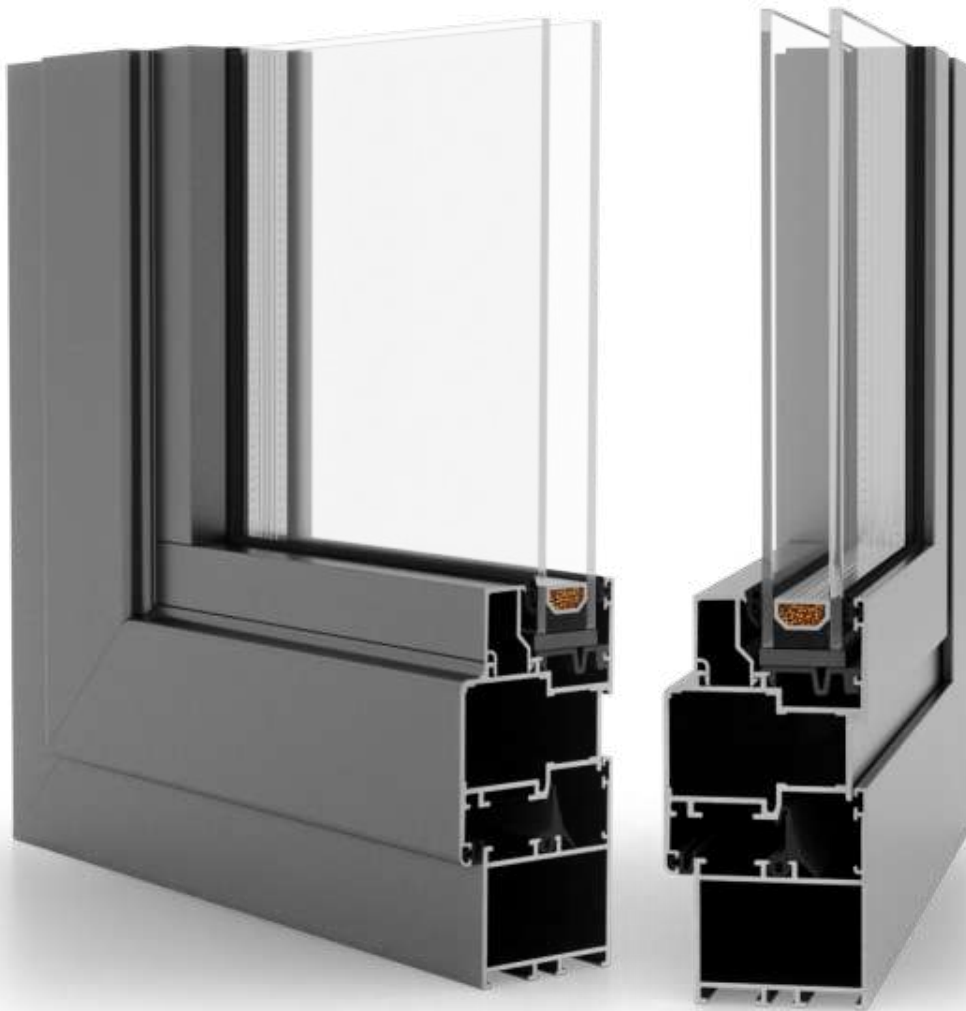

Designed primarily for interiors, the ECONOLINE system offers partition walls that can be joined at reasonable angle.

TECHNICAL DATA	ECONOLINE
Frame depth window/door	51 mm / 51 mm
Sash depth window/door	60 mm / 51 mm
Glazing thickness	up to 37mm
MAXIMUM DIMENSIONS AND WEIGHTS OF THE STRUCTURE	
Max. sash dimensions	Single-sash windows/doors: H 1400 mm L 2500 mm Double-sash windows: H 2400 mm L 2500 mm
Max. sash weight	120 kg

ECOFUTURAL

WINDOW AND DOOR SYSTEM



Ecofutural allows construction of shopfronts, single or double-sash turn windows, tilt-and-turn windows, as well as single or double-sash doors. The system also allows for the design and production of Monoblock type windows.

TECHNICAL DATA	ECOFUTURAL
Frame depth	65 mm
Sash depth	74 mm
Glazing / infill thickness	4 - 50 mm / 12 - 59 mm
VISIBLE PROFILE WIDTH FROM THE OUTSIDE	
Door frame / profile height	61,5 mm (door) / 55 mm; 65 mm (window)
Door sash / wall sash	88,5 mm (door); from 40 mm (window)
MAXIMUM DIMENSIONS AND WEIGHTS OF THE STRUCTURE	
Max. sash dimensions	H 1400 mm L 2600 mm
Max. sash weight (door / window)	150 kg / 120 kg

ECOFUTURAL OC

WINDOW AND DOOR SYSTEM



The ECOFUTURAL OC window and door system stands out among aluminium solutions for its excellent thermal parameters. Aesthetically, it is an attractive solution due to the shape of the frames, which conceal the full height of the profiles.

TECHNICAL DATA	ECOFUTURAL OC
Frame depth	65 mm
Sash depth	74 mm
Glazing thickness (frame / sash)	4 - 50 mm / 12 - 59 mm
MAXIMUM DIMENSIONS AND WEIGHTS OF THE STRUCTURE	
Max. sash dimensions	H 2150 mm L 1200 mm
Max. sash weight window / door	120 kg / 150 kg

IMPERIAL

WINDOW AND DOOR SYSTEM



The energy-efficient IMPERIAL system is used for constructing windows, doors, and shopfronts. Its durable yet malleable profiles are perfectly suited for creating elements with unconventional shapes, such as arches.

TECHNICAL DATA	IMPERIAL
Frame depth	65 mm
Sash depth	74 mm
Glazing thickness	4 - 51 mm
MAXIMUM DIMENSIONS AND WEIGHTS OF THE STRUCTURE	
Max. sash dimensions	1 track: H 1300 mm L 2752 mm 2 tracks: H 2200 mm L 2400 mm 3 tracks: H 3500 mm L 2400 mm
Max. sash weight	120 kg

GENESIS

WINDOW AND DOOR SYSTEM



The Genesis system enables the design of modern windows, doors, shopfronts, and partition walls, characterized by high functionality. The system sets a new standard for window insulation while maintaining high ergonomics.

TECHNICAL DATA	GENESIS
Frame depth	75 mm
Sash depth	84 mm
Infill thickness	9 - 65 mm
VISIBLE PROFILE WIDTH FROM THE OUTSIDE	
Wall frame	from 55 mm
Wall transom (or mullion)	from 42,5 mm
MAXIMUM DIMENSIONS AND WEIGHTS OF THE STRUCTURE	
Max. sash dimensions	H 1600 mm L 2600 mm
Max. sash weight (door / window)	160 kg

SUPERIAL

WINDOW AND DOOR SYSTEM

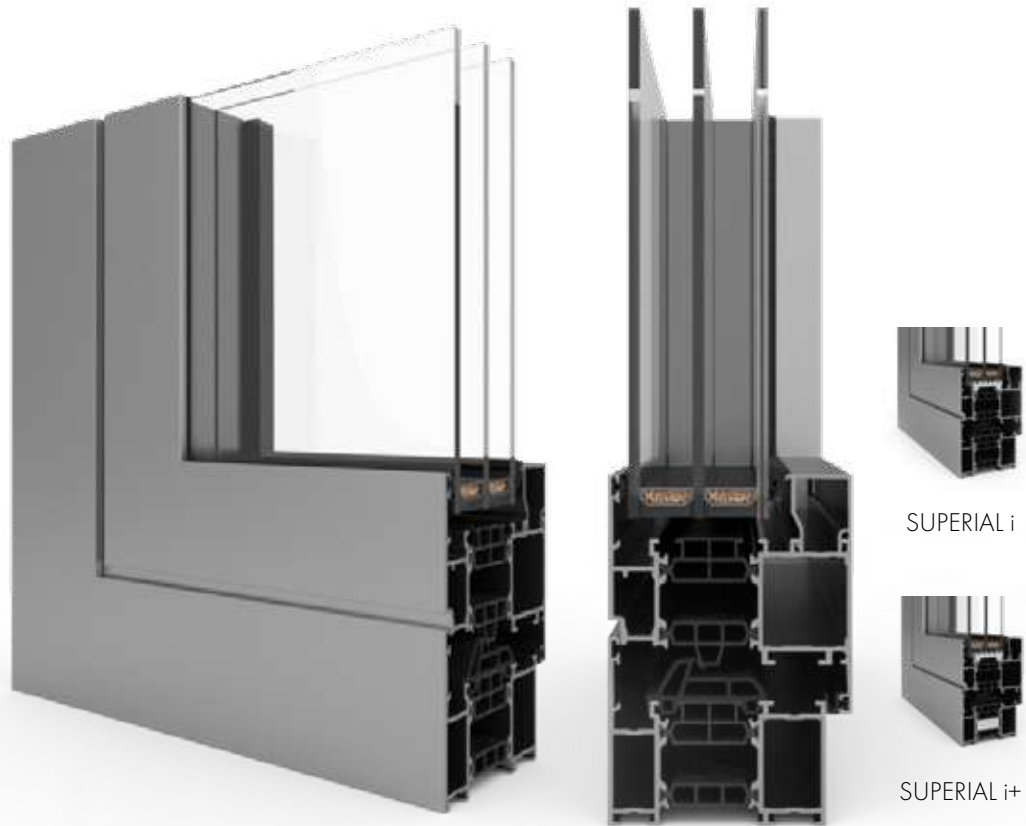

Due to its design, the Superial system is ideal for producing windows, external shopfronts, turn only, tilt-and-turn, tilt, and tilt-and-slide windows, as well as inward-opening doors based on a modified window sash. Windows based on this very system can also be used in the creation of facade systems.

TECHNICAL DATA	SUPERIAL
Frame depth	75 mm
Sash depth window / door	84 mm / 75 mm
Infill thickness	14 - 61 mm
VISIBLE PROFILE WIDTH FROM THE OUTSIDE	
Door frame / wall frame	61,5 mm / from 55 mm
Door sash / wall sash	88,5 mm / from 40 mm
MAXIMUM DIMENSIONS AND WEIGHTS OF THE STRUCTURE	
Max. door sash dimensions	H 1600 mm L 2600 mm
Max. sash weight (door / window)	200 kg / 150 kg

MAXLIGHT

WINDOW AND DOOR SYSTEM

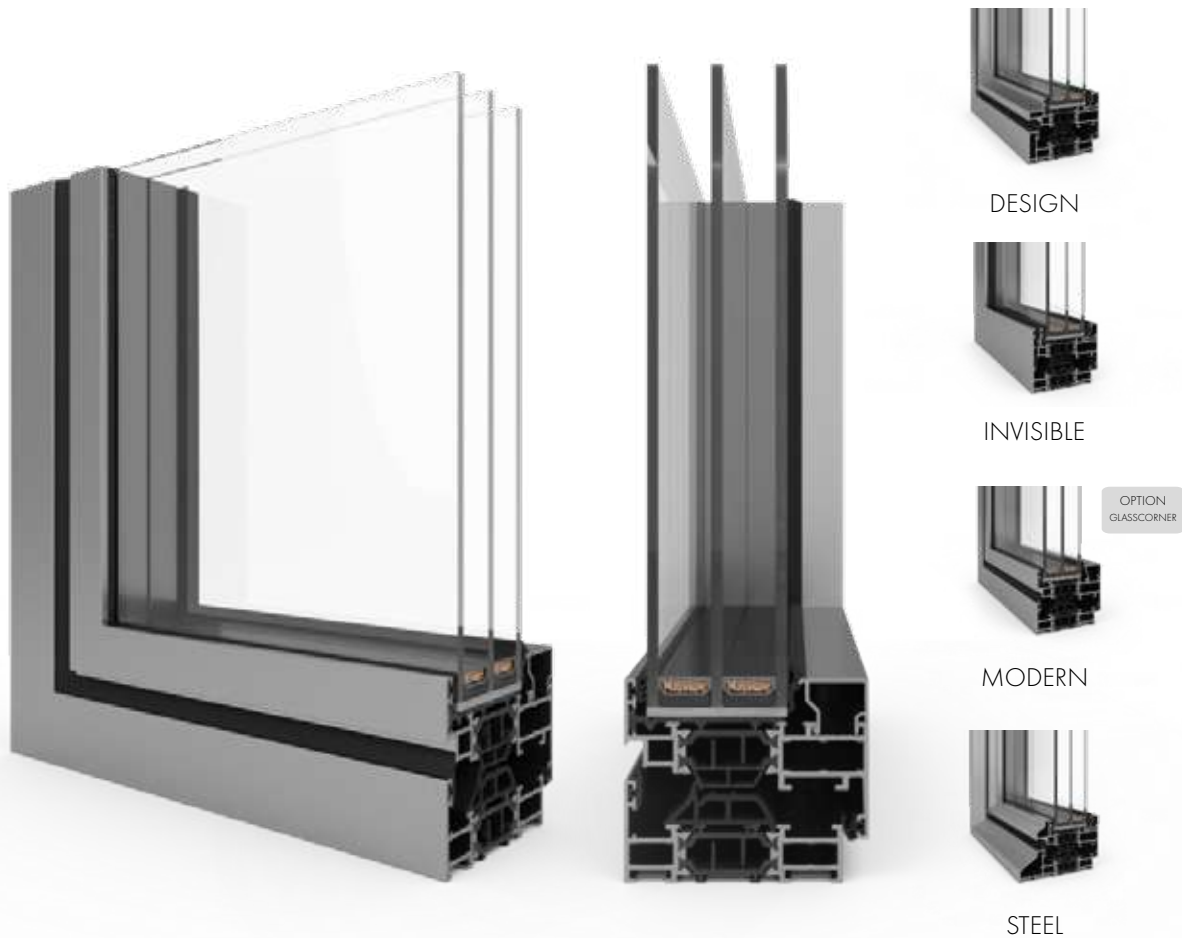

Maxlight is a solution for modern architectural projects, combining slim profiles with minimalist design and excellent parameters. It is suitable for both private homes and public utility buildings. It provides maximum access to natural light and is available in four different variants, offering unique structural and visual features.

TECHNICAL DATA	DESIGN	INVISIBLE	MODERN	STEEL
Frame depth	83 mm	75 mm	75 mm	105 mm
Sash depth	92 mm	84 mm	84 mm	97 mm
Infill thickness	up to 59 mm	up to 59 mm	up to 68 mm	up to 59 mm
Glazing bead height	15 mm	15 mm	15 mm	15 mm
VISIBLE PROFILE DIMENSIONS FROM THE OUTSIDE				
Min. width of inward-opening window	frame: 35 mm sash: 35 mm	frame (hidden sash) 70 mm	frame: 35 mm sash: 35 mm	frame: 35 mm sash: 35 mm
Min. width of inward-opening door	frame: 35 mm sash: 68 mm		frame: 35 mm sash: 35 mm	frame: 35 mm sash: 35 mm
Min. width of outward-opening door	frame: 15 mm sash: 88 mm		frame: 15 mm sash: 88 mm	frame: 15 mm sash: 88 mm

VS 600

GUILLOTINE SYSTEM



VS 600 features a spring-based hardware mechanism that allows the sashes to be moved up and down. The use of additional hardware allows the sashes to be tilted.

TECHNICAL DATA	VS 600
Frame depth	130,5 mm
Sash depth	52 mm
Infill thickness	24 - 28 mm
VISIBLE PROFILE WIDTH FROM THE OUTSIDE	
Door frame / wall frame	22 mm
Door sash / wall transom	40,5 mm
MAXIMUM DIMENSIONS AND WEIGHTS OF THE STRUCTURE	
Max. sash dimensions	H 1150 mm L 1500 mm
Max. sash weight	27 kg

SLIDE GLASS

SLIDING DOOR SYSTEM



SLIDE GLASS is a sliding system for modern interiors (it lacks a thermal break), where users expect ergonomics and an attractive design highlighted by abundant natural light. It is also used as an element in pergolas, creating walls that protect users from the wind.

TECHNICAL DATA	SLIDE GLASS
Frame depth	71,1 - 115,5 mm
Infill thickness	10 mm
VISIBLE PROFILE WIDTH FROM THE OUTSIDE	
Frame	6,3 mm
Sash	61 mm
MAXIMUM DIMENSIONS AND WEIGHTS OF THE STRUCTURE	
Max. sash dimensions	H 2600 mm L 1100 mm
Max. sash weight	80 kg

MODERNSLIDE

LIFT-AND-SLIDE DOOR SYSTEM

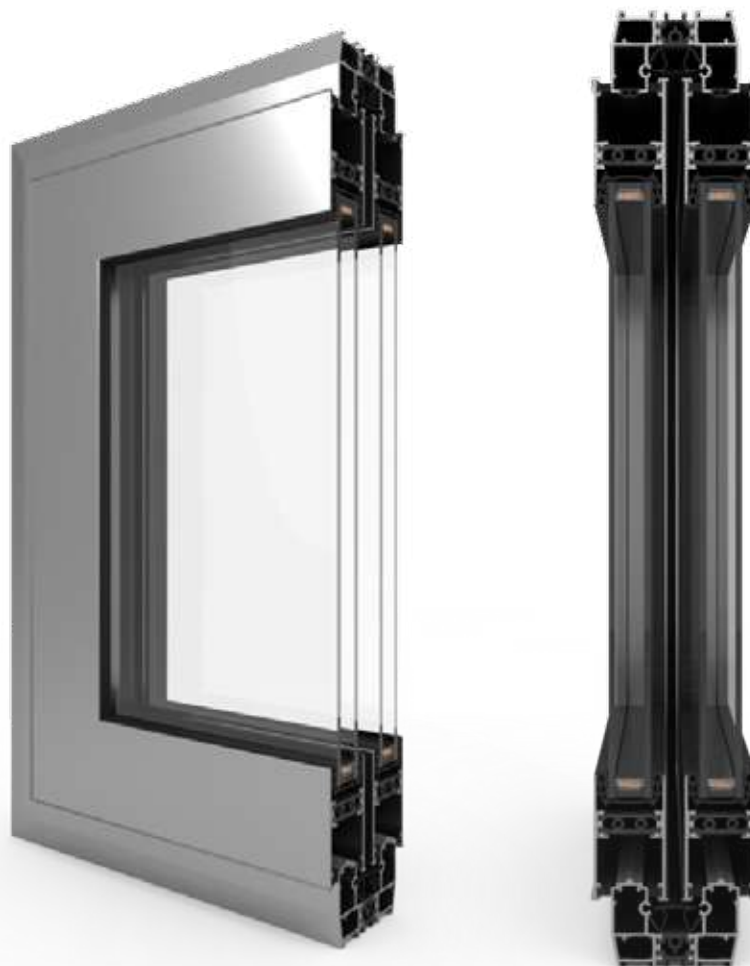

OPTION
MONOBLOCK

The system is designed for building sliding and lift-and-slide systems (with a high or low threshold). The structure can consist of up to six elements and move on two or three tracks.

TECHNICAL DATA	MODERNSLIDE
Frame depth	65 (2-track profile) - 117 (3-track profile), 196 mm (for Monoblock version)
Sash depth	44 mm
Infill thickness	24, 28 or 32 mm
VISIBLE PROFILE WIDTH FROM THE OUTSIDE	
Door frame / wall frame	47 mm
Door sash / wall transom	71,2 mm
MAXIMUM DIMENSIONS AND WEIGHTS OF THE STRUCTURE	
Max. door sash dimensions	H 1700 mm L 2400 mm
Max. sash weight	250 kg

VISOGLIDE

LIFT-AND-SLIDE DOOR SYSTEM

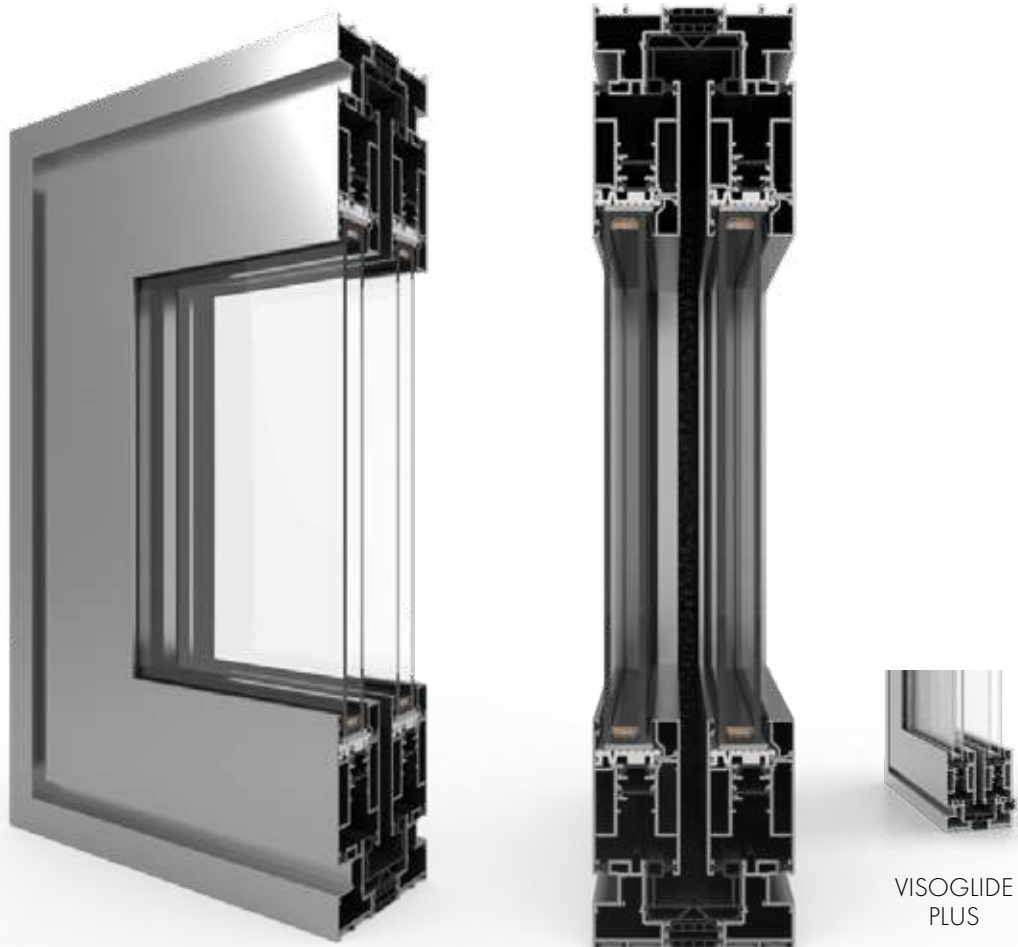

The system enables the creation of sliding and lift-and-slide structures, offering both high and low threshold variants. This solution allows for the installation of up to six sashes operating in double- or triple-track configurations.

TECHNICAL DATA	VISOGLIDE
Frame depth standard / special / monorail	117,7 / 125,4 / 141,6 mm
Sash depth	51 mm
Infill thickness	6 - 36 mm
VISIBLE PROFILE WIDTH FROM THE OUTSIDE	
Door frame / wall frame	27,5 mm / 52 mm
Door sash / wall transom	90 mm
MAXIMUM DIMENSIONS AND WEIGHTS OF THE STRUCTURE	
Max. sash dimensions	H 1700 mm L 2400 mm
Max. sash weight	250 kg

VISOGLIDE PLUS

SLIDING DOOR SYSTEM



The VG PLUS sliding system offers the possibility of creating classic sliding and lift-and-slide structures. It incorporates thermal breaks, which, combined with high tightness, allow for the creation of even very large partitions, consisting of a maximum of six elements moving on three tracks.

TECHNICAL DATA	VG PLUS
Frame depth (1-3 tracks)	118 mm / 142 mm / 184 mm
Sash depth	51 mm
Glazing thickness (frame / sash)	6 - 36 mm / 18 - 60 mm
MAXIMUM DIMENSIONS AND WEIGHTS OF THE STRUCTURE	
Max. sash dimensions	H 3000 mm L 2500 mm
Max. sash weight	Sliding 250 kg / Lift-and-slide 200 kg

ULTRAGLIDE

LIFT-AND-SLIDE DOOR SYSTEM

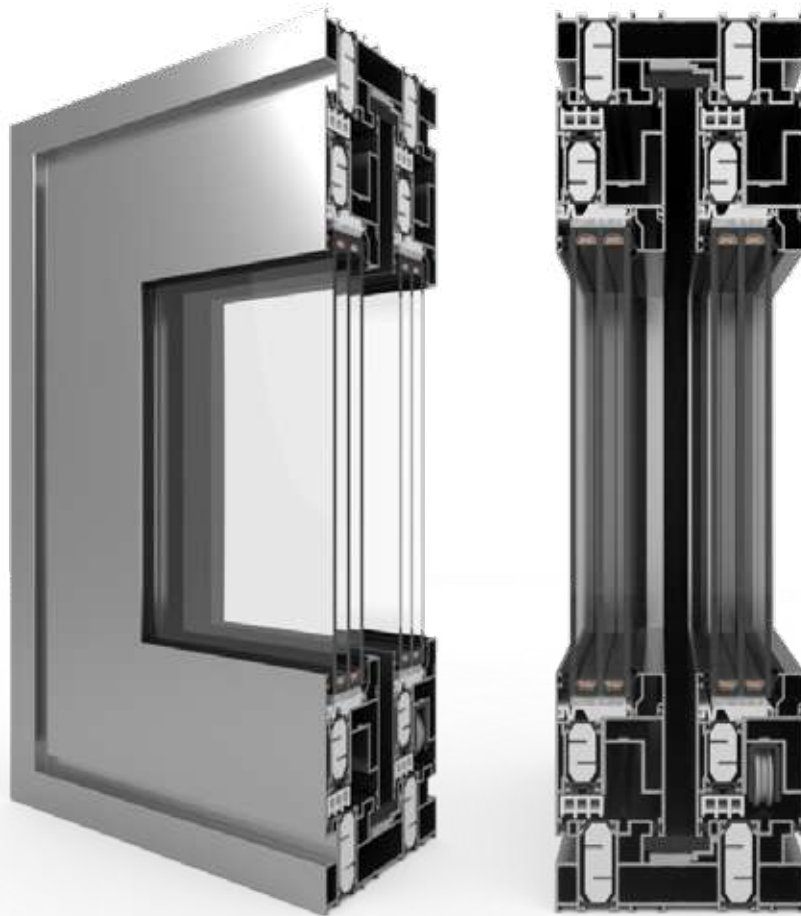

The system allows for the creation of large glazed areas, ensuring excellent interior lighting and facilitating their arrangement. Additionally, thanks to the use of a thermal break with widths of 22 and 28 mm with fiberglass, the structure is stable, functional, and relatively lightweight.

TECHNICAL DATA	ULTRAGLIDE
Frame depth	153 - 239 mm
Sash depth	67 mm
Infill thickness	14 - 52 mm
VISIBLE PROFILE WIDTH FROM THE OUTSIDE	
Door frame / wall frame	30 mm / 56,5 mm
Door sash / wall transom	100 mm
MAXIMUM DIMENSIONS AND WEIGHTS OF THE STRUCTURE	
Max. sash dimensions	H 2800 mm L 3000 mm
Max. sash weight	400 kg

ULTRAGLIDE MAX LIGHT MONORAIL

LIFT-AND-SLIDE DOOR SYSTEM

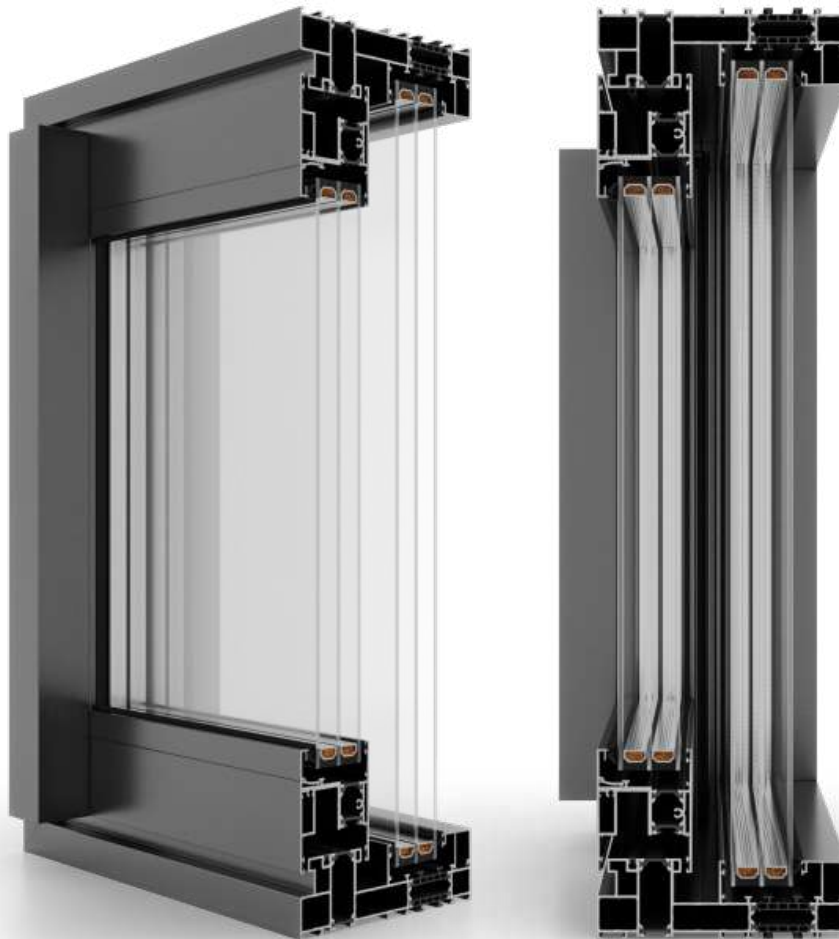

This is a high-quality sliding system with a thermal break, designed for large glass surfaces. It meets the highest standards for thermal and acoustic insulation.

TECHNICAL DATA	ULTRAGLIDE MAX LIGHT MONORAIL
Frame depth	176 mm
Sash depth	67 mm
Infill thickness	15 - 51 mm
VISIBLE PROFILE WIDTH FROM THE OUTSIDE	
Door frame / wall frame	55 mm
Movable mullion	45 mm
MAXIMUM DIMENSIONS AND WEIGHTS OF THE STRUCTURE	
Max. sash dimensions	H 2800 mm L 3000 mm
Max. sash weight	440 kg

PANORAMA

FOLDING DOOR SYSTEM



The system allows for the use of two to eight sashes. They move along tracks that guide the entire mechanism. Inward and outward folding option.

TECHNICAL DATA	PANORAMA
Frame depth	74,5 mm
Sash depth	74,5 mm
Infill thickness	16 - 50 mm
VISIBLE PROFILE WIDTH FROM THE OUTSIDE	
Door frame	57,5 mm
Door sash / wall transom	73 mm
MAXIMUM DIMENSIONS AND WEIGHTS OF THE STRUCTURE	
Max. sash dimensions	H 1200 mm L 2500 mm
Max. sash weight	100 kg

FR 65 EI

INTERNAL FIRE-RATED* PARTITION SYSTEM



FR 65 EI offers the ability to create internal fire-rated and smoke-proof partitions. It does not have thermal breaks, so it provides very limited protection against heat loss and is not recommended for use on external walls. The maximum fire protection level for walls is EI 60, and for doors - EI 30, which has been confirmed by the B certificate.

TECHNICAL DATA	FR 65 EI
Frame depth	65 mm
Sash depth	65 mm
Glazing thickness	17 - 25 mm
MAXIMUM DIMENSIONS AND WEIGHTS OF THE STRUCTURE	
Max. sash weight	160 kg

*system availability depends on the market and possessed certification.

FR 90 EI

SMOKE-TIGHT FIRE-RATED* WINDOW AND DOOR SYSTEM



FR 90 EI is a thermally insulated fire-rated system that can achieve a fire resistance class of EI 15, 30, 45, or 60 for fire walls in accordance with PN-EN 14351-1+A2:201, and even EI90 for internal and external doors. Due to the use of a thermal break, the FR 90 EI system can be used for both internal and external partitions.

TECHNICAL DATA	FR 90 EI
Frame depth	90 mm
Sash depth	90 mm
Glazing thickness	up to 60 mm

*system availability depends on the market and possessed certification.



EXTENSION PROFILES

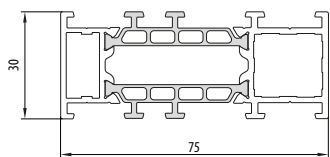

ALIPLAST GN070

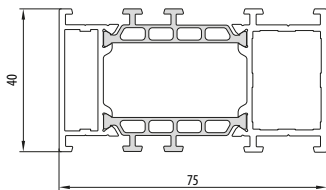

ALIPLAST GN071

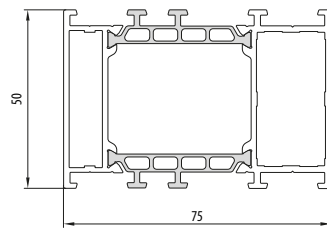

ALIPLAST GN072

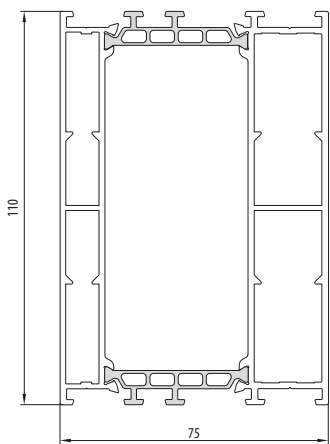

ALIPLAST GN075

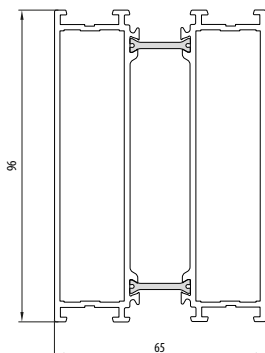

ALIPLAST IP176

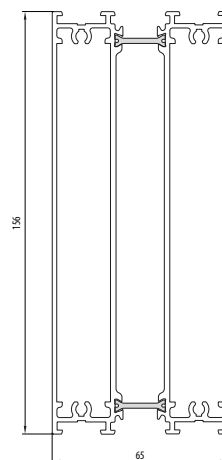

ALIPLAST IP177

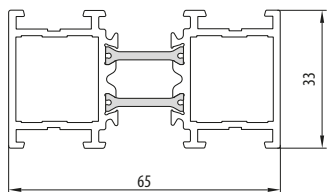

ALIPLAST IP173

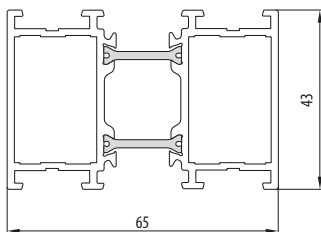

ALIPLAST IP174

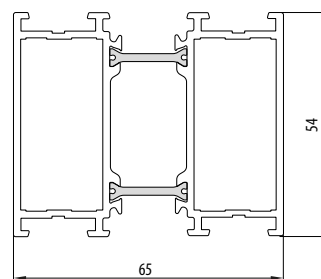

ALIPLAST IP175

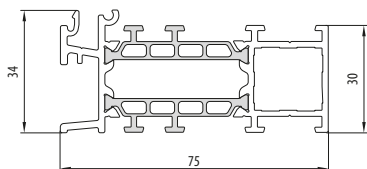

ALIPLAST GN090

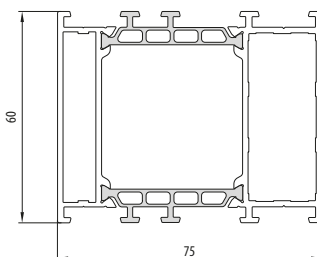

ALIPLAST GN073

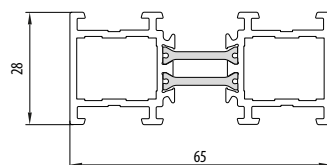

ALIPLAST IP178

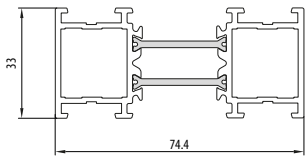

ALIPLAST SP173

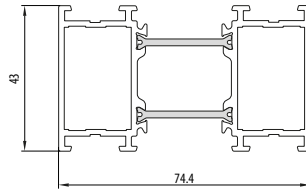

ALIPLAST SP174

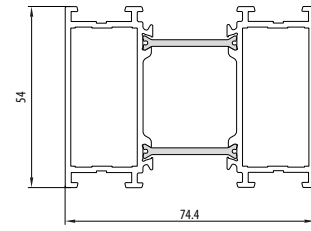

ALIPLAST SP175

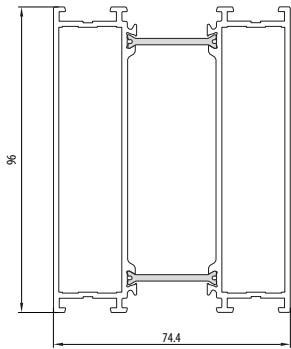

ALIPLAST SP176

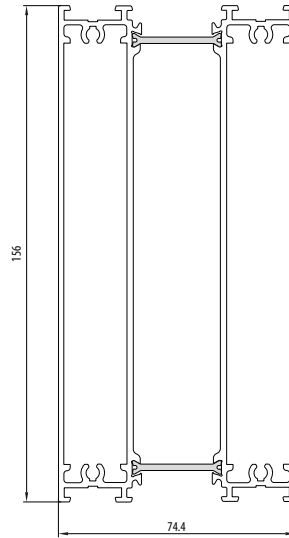

ALIPLAST SP177

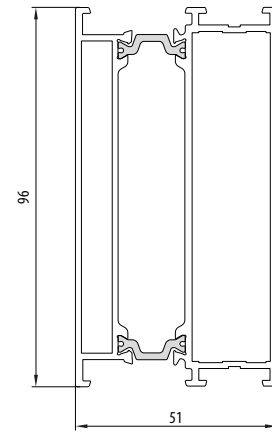

ALIPLAST TL176

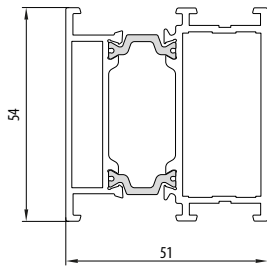

ALIPLAST TL175

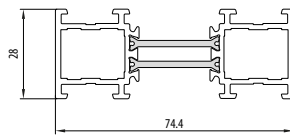

ALIPLAST SP178

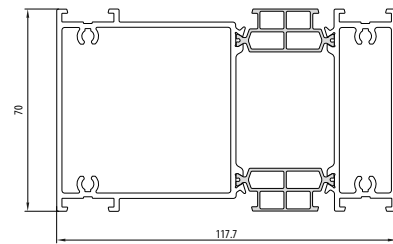

ALIPLAST VG576

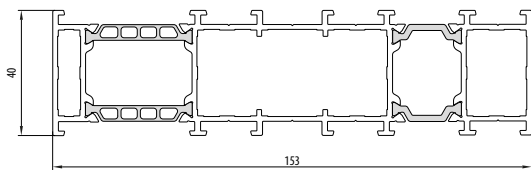

ALIPLAST UG1810

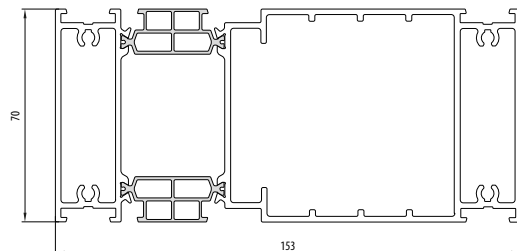

ALIPLAST UG176

DECEUNINCK SYSTEMS



ENTRA	52
DECALU 88 STANDARD	53
DECALU 88 HIDDEN	54
DECALU 94 RETRO	55
DECALU 110 STEEL	56
DECALU 88 DOORS	57
DECALU 88 FOLDING DOORS	58
DECALU 163 SLIDE	59
EXTENSION PROFILES	60



ENTRA

WINDOW SYSTEM



The simplified design of the Entra system allows for exceptional performance parameters, very large dimensions for single windows, and remarkable aesthetics. It is suitable for new investments and for the renovation of older structures. Three thermal versions of the profiles allow for the selection of the ideal solution, regardless of the level of energy efficiency required by the client.

TECHNICAL DATA	ENTRA
Frame depth Standard / Steel (Flat)	73 mm / 95 mm
Sash depth	82 mm
Glazing thickness/ fix	8-63 mm / 5-54 mm
MINIMUM VISIBLE PROFILE WIDTH	
Frame	43 mm
Sash	31 mm
MAXIMUM DIMENSIONS AND WEIGHTS OF THE STRUCTURE	
Max. window dimensions	H 2650 mm L 1250 mm
Max. sash weight	150 kg

DECALU 88 STANDARD

WINDOW AND DOOR SYSTEM



This innovative solution is perfect for the production of monoblock and renovation windows. Thanks to a patented method of installing fittings using a PVC profile, they operate incredibly smoothly and are effectively protected against corrosion.

TECHNICAL DATA	DECALU 88 STANDARD
Frame depth (window / door)	88 mm
Sash depth (window / door)	96 mm / 88 mm
Glazing thickness (door and fixed windows / opening windows)	up to 71 mm
MINIMUM VISIBLE PROFILE WIDTH	
Frame (window / door)	43 mm / 75,7 mm
Sash (window / door)	31 mm / 71 mm
MAXIMUM DIMENSIONS AND WEIGHTS OF THE STRUCTURE	
Max. window dimensions	H 2650 mm L 1200 mm
Max. sash dimensions	H 1300 mm L 2500 mm
Max. sash weight (window / door)	100-120 kg / 160 kg

DECALU 88 HIDDEN

WINDOW SYSTEM



A system utilizing patented "hidden sash" solutions. Combinations of sashes with fixed glazing in various configurations look identical, allowing for the creation of attractive, uniform facades.

TECHNICAL DATA	DECALU 88 HIDDEN
Frame depth	88 mm
Sash depth	97 mm
Glazing thickness (fixed window / opening windows)	up to 71 mm
MINIMUM VISIBLE PROFILE WIDTH	
Frame	81,5 mm
Sash	43 mm (invisible)
MAXIMUM DIMENSIONS AND WEIGHTS OF THE STRUCTURE	
Max. window dimensions	H 2650 mm L 1200 mm
Max. sash weight	100 kg (Heavy Duty hardware: 120 kg)

DECALU 94 RETRO

WINDOW SYSTEM



The Decalu 94 Retro system is designed for the production of windows that closely resemble retro-style wooden windows. Additional features that enhance the aesthetic appeal of the joinery include concealed hinges, no visible gasket, and invisible drainage.

TECHNICAL DATA	DECALU 94 RETRO
Frame depth	94 mm
Sash depth	103 mm
Glazing thickness (fixed window / opening windows)	up to 71 mm
MINIMUM VISIBLE PROFILE WIDTH	
Frame	43 mm
Sash	31 mm
MAXIMUM DIMENSIONS AND WEIGHTS OF THE STRUCTURE	
Max. window dimensions	H 2650 mm L 1200 mm
Max. sash weight	100 kg (Heavy Duty hardware: 120 kg)

DECALU 110 STEEL

WINDOW SYSTEM

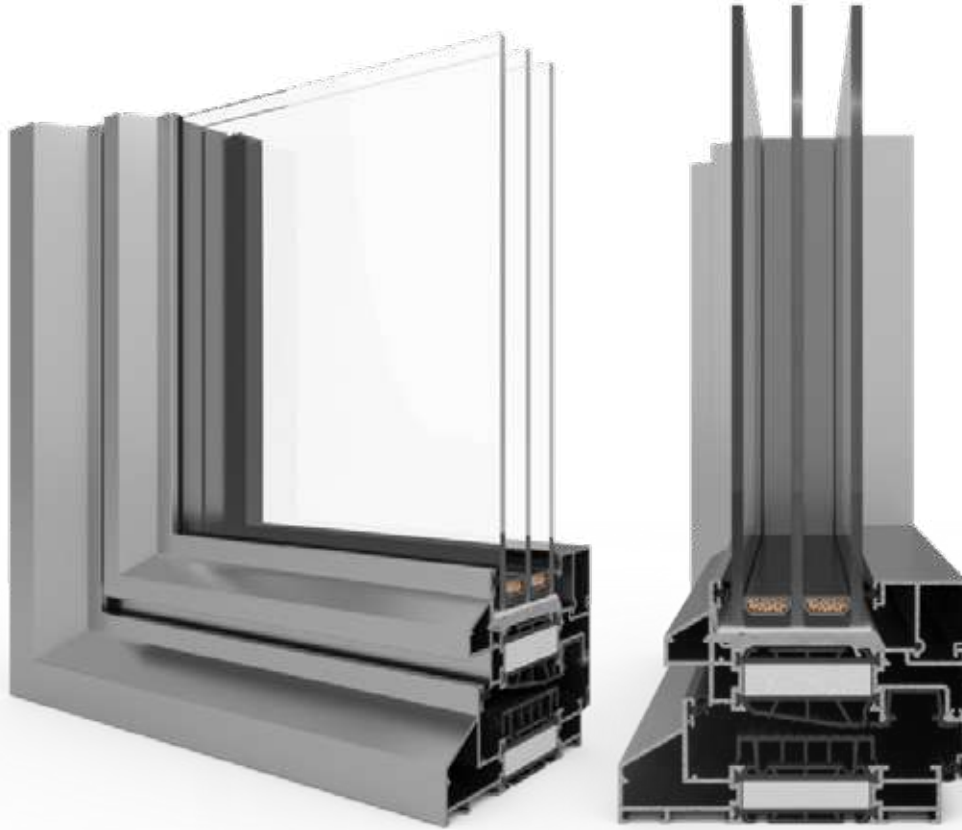

The distinctively bevelled profiles are reminiscent of steel joinery in their appearance. Windows can be constructed based on either a fixed or a movable mullion.

TECHNICAL DATA	DECALU 110 STEEL
Frame depth	110 mm
Sash depth	103,5 mm
Glazing thickness	up to 61 mm
MINIMUM VISIBLE PROFILE WIDTH	
Frame	43 mm
MAXIMUM DIMENSIONS AND WEIGHTS OF THE STRUCTURE	
Max. window dimensions	H 2650 mm L 1200 mm
Max. sash weight	100 kg (Heavy Duty hardware: 120 kg)

DECALU 88 DOORS

DOOR SYSTEM

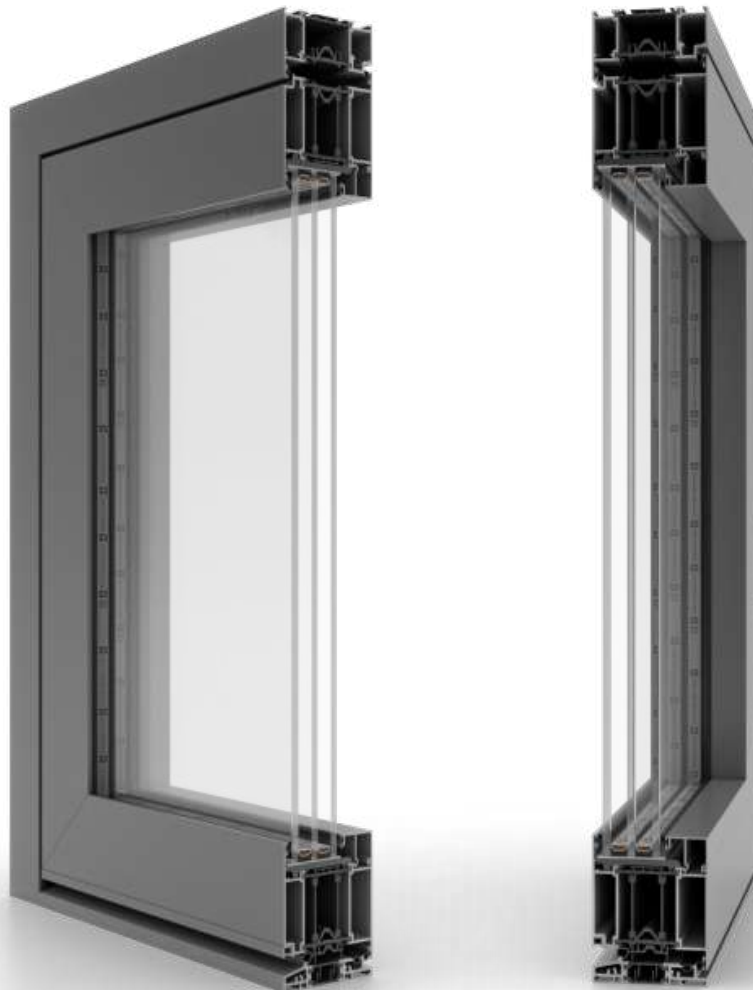

Decalu 88 Doors are energy-efficient and durable aluminium doors with a low heat transfer coefficient of $0,9 \text{ W/m}^2$ for dimensions of $1200 \times 2500 \text{ mm}$. The anti-bimetal thermal break prevents door deformation, and well-thought-out structural solutions allow for the installation of hinges.

TECHNICAL DATA	DECALU 88 DOORS
Frame depth	88 mm
Sash depth	88 mm
Glazing thickness	up to 62 mm
MAXIMUM DIMENSIONS AND WEIGHTS OF THE STRUCTURE	
Max. door dimensions	H 1400 mm L 2900 mm
Max. sash weight	160 kg

DECALU 88 FOLDING DOORS

FOLDING DOOR SYSTEM

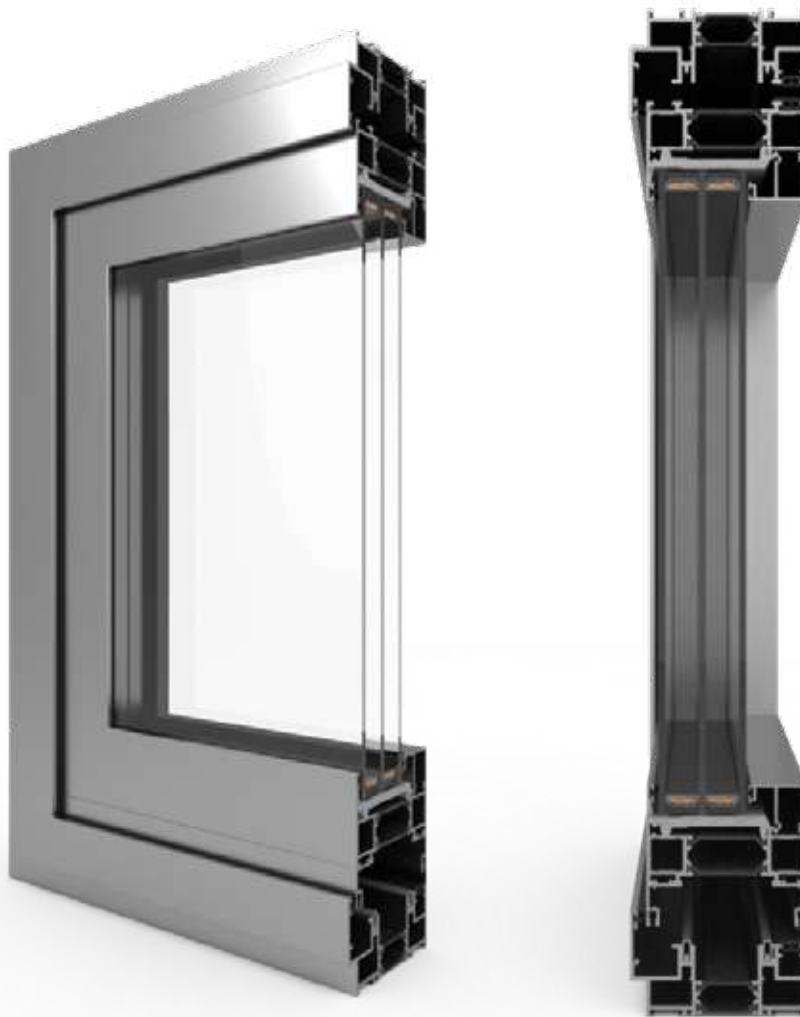

This system allows for the creation of structures up to 3 meters high and 6.5 meters wide. A specially designed adjustment profile allows all sashes to be made in the same width. Inward and outward folding options available.

TECHNICAL DATA	DECALU 88 FOLDING DOORS
Installation depth	88 mm
Infill thickness	up to 62 mm
MAXIMUM DIMENSIONS AND WEIGHTS OF THE STRUCTURE	
Max. sash dimensions	L 1200 mm H 3000 mm
Max. sash weight	150 kg

DECALU 163 SLIDE

LIFT-AND-SLIDE DOOR SYSTEM

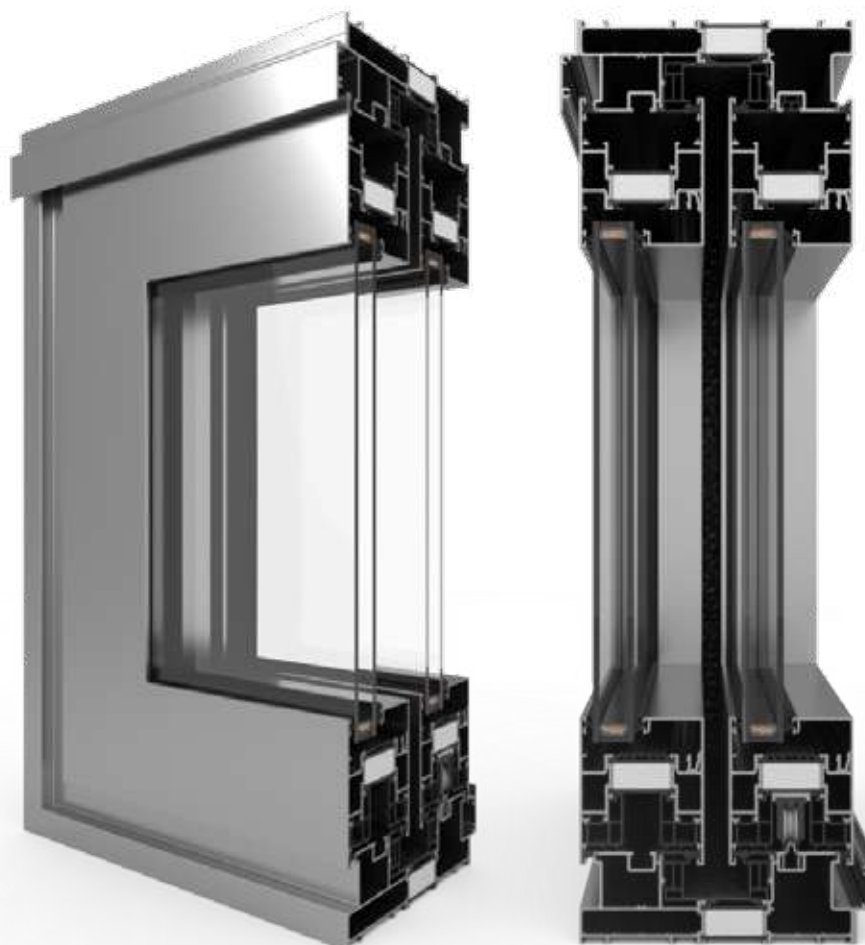

Thanks to the slim profiles of the frames and sashes, the glazed surface area is significantly larger. The visible width of the movable mullion is only 73 mm, which adds elegance to the entire structure.

TECHNICAL DATA	DECALU 163 SLIDE
Installation depth	163 mm
Infill depth	58 mm
MINIMUM VISIBLE PROFILE WIDTH	
Movable mullion	73 mm
Track/frame height	55 mm
Sash height	88 mm
MAXIMUM DIMENSIONS AND WEIGHTS OF THE STRUCTURE	
Max. window dimensions	H 3200 mm L 3300 mm
Max. sash weight	400 kg

EXTENSION PROFILES

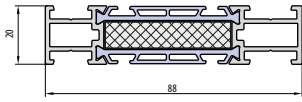

P-B88-A6000

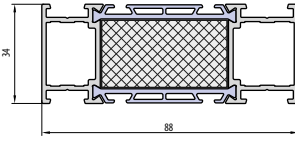

P-B88-A6010

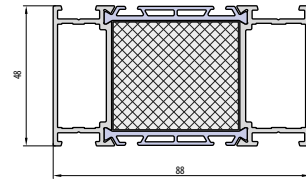

P-B88-A6020

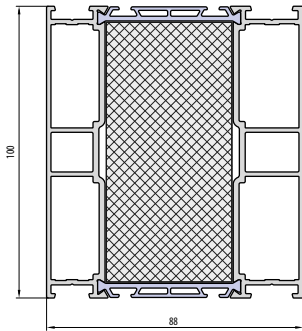

P-B88-A6040

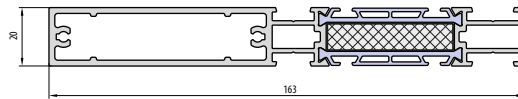

P-B88-A6011

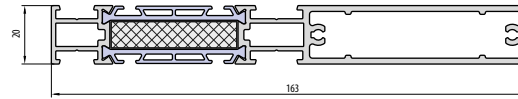

P-B88-A6012

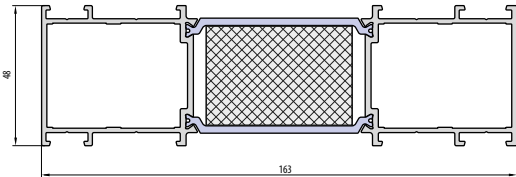

P-163-6000

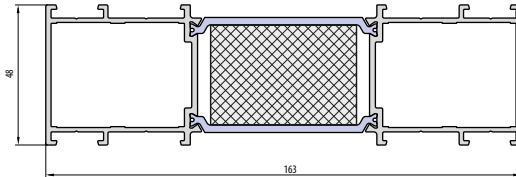

P-163-6001

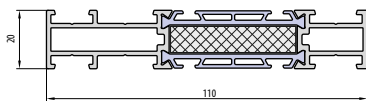

P-B88-A6200

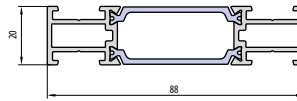

P-97-6000

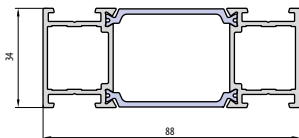

P-97-6010

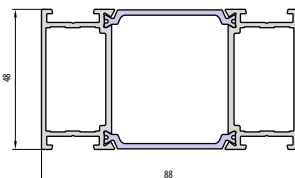

P-97-6020

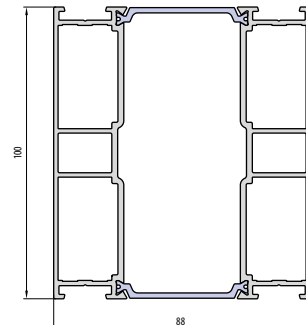

P-97-6040



CORTIZO SYSTEMS



COR 70 INDUSTRIAL	64
COR 70 HO	65
CORTIZO CASEMENT	66
2000 CORREDERA	67
4900 CORREDERA	68
COR VISION	69
COR VISION PLUS	70
CORTIZO BIFOLD PLUS	71
MILLENNIUM PLUS PIVOT	72
COR VISION GALANDAGE	73
EXTENSION PROFILES	74



COR 70 INDUSTRIAL

WINDOW AND DOOR SYSTEM



The Industrial version of the COR 70 system presents a minimalist design inspired by steel. Thanks to a 35 mm thermal break and triple-glazed units, it provides exceptional thermal and acoustic insulation, ideal for modern spaces and passive buildings.

TECHNICAL DATA	COR 70 INDUSTRIAL
Installation depth	70 mm
Thermal break thickness	35 mm
Max. glazing thickness	55 mm
MAXIMUM DIMENSIONS AND WEIGHTS OF THE STRUCTURE	
Max. sash dimensions	H 2600 mm L 1500 mm
Max. sash weight	160 kg

COR 70 HO

WINDOW SYSTEM



The COR 70 HO window system is characterized by its very large glazed areas, which can be achieved thanks to its slim profiles. Glass can occupy up to 85% of its surface, which translates to the maximum amount of light entering the interior.

TECHNICAL DATA	COR 70 HO
Frame depth	70 mm
Sash depth	70 mm
Glazing thickness	up to 46 mm
MAXIMUM DIMENSIONS AND WEIGHTS OF THE STRUCTURE	
Max. sash dimensionsokna (H×L)	1300 x 2400 mm / 1200 x 3500 mm (HD turn hardware)
Max. sash weight	160 kg

CORTIZO CASEMENT

WINDOW SYSTEM



The Cortizo Casement system features comprehensively designed outward-opening windows with narrow aluminium profiles. They provide more light and meet strict safety standards. Thanks to a thermal break, they offer excellent thermal and acoustic insulation. A wide range of RAL colours offers a variety of finishes. They are equipped with special hardware for easy daily use and maintenance.

TECHNICAL DATA	CORTIZO CASEMENT
Frame depth	70 mm
Sash depth	70 mm
Glazing thickness (fixed window / opening windows)	14 - 44 mm
MINIMUM VISIBLE PROFILE WIDTH	
Frame	15 mm
Sash	50 mm
MAXIMUM DIMENSIONS AND WEIGHTS OF THE STRUCTURE	
Max. window dimensions (Top Hung)	H 1800 mm L 1800 mm
Max. sash weight	100 kg

2000 CORREDERA

SLIDING DOOR SYSTEM



The Corredera 2000 sliding system is an ideal solution for home and office interiors, allowing for the construction of doors with up to six sashes. With the GALANDAGE option, the movable sashes can retract into the wall, providing maximum space and an elegant look.

TECHNICAL DATA	2000 CORREDERA
Installation depth	45 - 80 mm
Infill thickness	up to 17 mm
MAXIMUM DIMENSIONS AND WEIGHTS OF THE STRUCTURE	
Max. sash dimensions	H 2600 mm L 1600 mm
Max. sash weight	100 kg

4900 CORREDERA

SLIDING DOOR SYSTEM



The elegant form of this sliding system's straight edges, combined with a narrow central mullion, creates a unique and modern structure. The use of optional reinforcements on the sashes allows for the construction of large-scale arrangements with up to four movable elements. Thanks to a thermal break and glazing up to 36 mm thick, the 4900 CORREDERA can achieve good thermal and acoustic parameters.

TECHNICAL DATA	4900 CORREDERA
Installation depth	70 - 126 mm
Glazing thickness	up to 36 mm
MAXIMUM DIMENSIONS AND WEIGHTS OF THE STRUCTURE	
Max. sash dimensions	H 3000 mm L 2200 mm
Max. sash weight	240 kg

COR VISION

LIFT-AND-SLIDE DOOR SYSTEM



COR Vision embodies Spanish design, minimizing the visibility of profiles to just 9% of the structure, thereby maximizing the glazed area. The lack of a need for a corner mullion when joining sashes at a 90° angle and the single-track option enhance the aesthetics. The U_w factor can be as low as $1,3W/m^2K$.

TECHNICAL DATA	COR VISION
Installation depth	6 mm / 3-track - 182 mm
Infill thickness	26 - 30 mm
MAXIMUM DIMENSIONS AND WEIGHTS OF THE STRUCTURE	
Max. sash dimensions	H 3000 mm L 2500 mm
Max. sash weight	320 kg

COR VISION PLUS

LIFT-AND-SLIDE DOOR SYSTEM

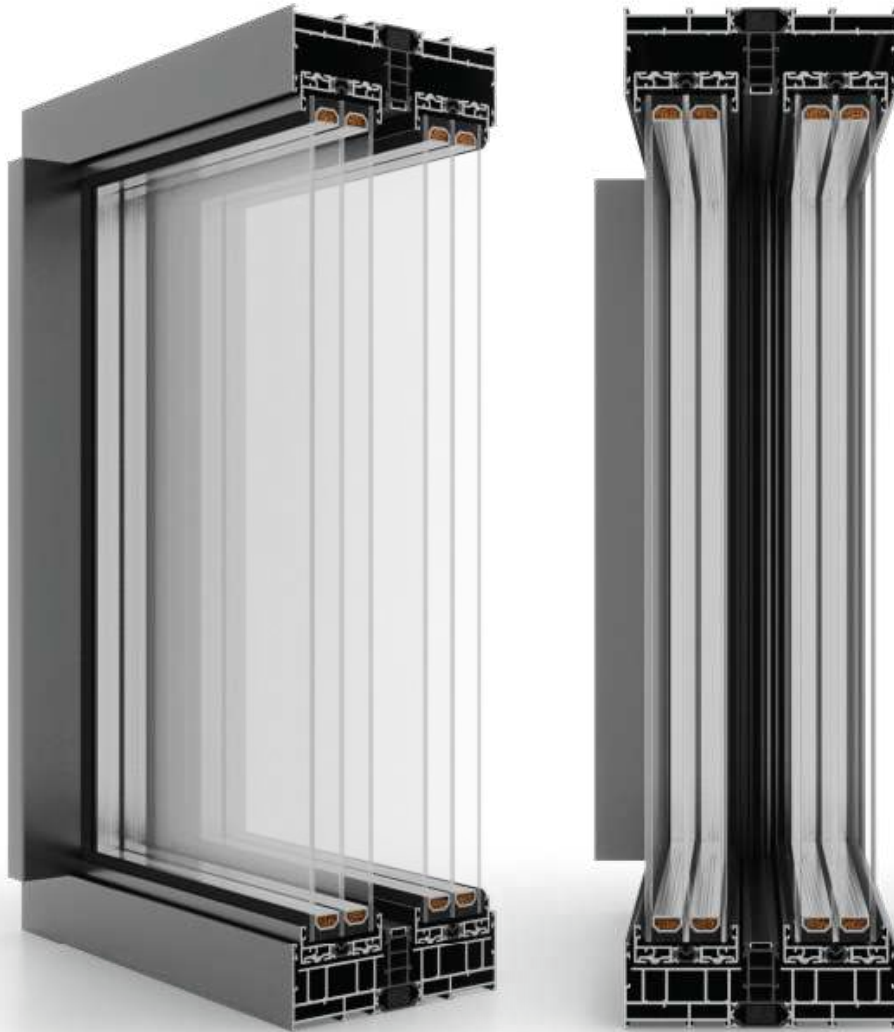

An advanced version of the COR Vision system, COR Vision Plus is designed for use in locations where very large glazed areas are planned. This prestigious system allows the glass surface to constitute as much as 94% of the opening. COR Vision Plus allows for the concealment of frames around the entire perimeter.

* depending on configuration - consult with a technologist

TECHNICAL DATA	COR VISION PLUS
Installation depth	180 mm / 3 track - 278 mm
Infill thickness	36 - 54 mm
MAXIMUM DIMENSIONS AND WEIGHTS OF THE STRUCTURE	
Max. sash dimensions	H 4000 mm* L 4000 mm*
Max. sash weight	400 kg (manual), 700kg (automatic)

CORTIZO BIFOLD PLUS

FOLDING DOOR SYSTEM



Cortizo Bifold Plus with thermal breaks effectively insulates against the cold. It can combine up to seven sashes, closing inwards or outwards in various configurations. The option of a lowered threshold or the use of linear drainage makes it ideal for both interiors and terraces. Inward and outward folding option.

TECHNICAL DATA	CORTIZO BIFOLD PLUS
Installation depth	80 mm
Infill thickness	up to 48 mm
MAXIMUM DIMENSIONS AND WEIGHTS OF THE STRUCTURE	
Max. sash dimensions	H 3000 mm L 1200 mm
Max. sash weight	120 kg

MILLENNIUM PIVOT PLUS

DOOR SYSTEM



The modern, uncompromising design of the Millennium Plus Pivot door is combined with the highest thermal and acoustic parameters, as well as functionality ensured by the offset pivot axis. They also allow for the creation of panel sidelights.

TECHNICAL DATA	MILLENNIUM PLUS PIVOT
Frame depth	80 mm
Sash depth	80 mm
Glazing thickness	up to 64 mm
MAXIMUM DIMENSIONS AND WEIGHTS OF THE STRUCTURE	
Max. sash dimensions	H 3000 mm L 2000 mm
Max. sash weight	250 kg

COR VISION GALANDAGE

SLIDING DOOR SYSTEM

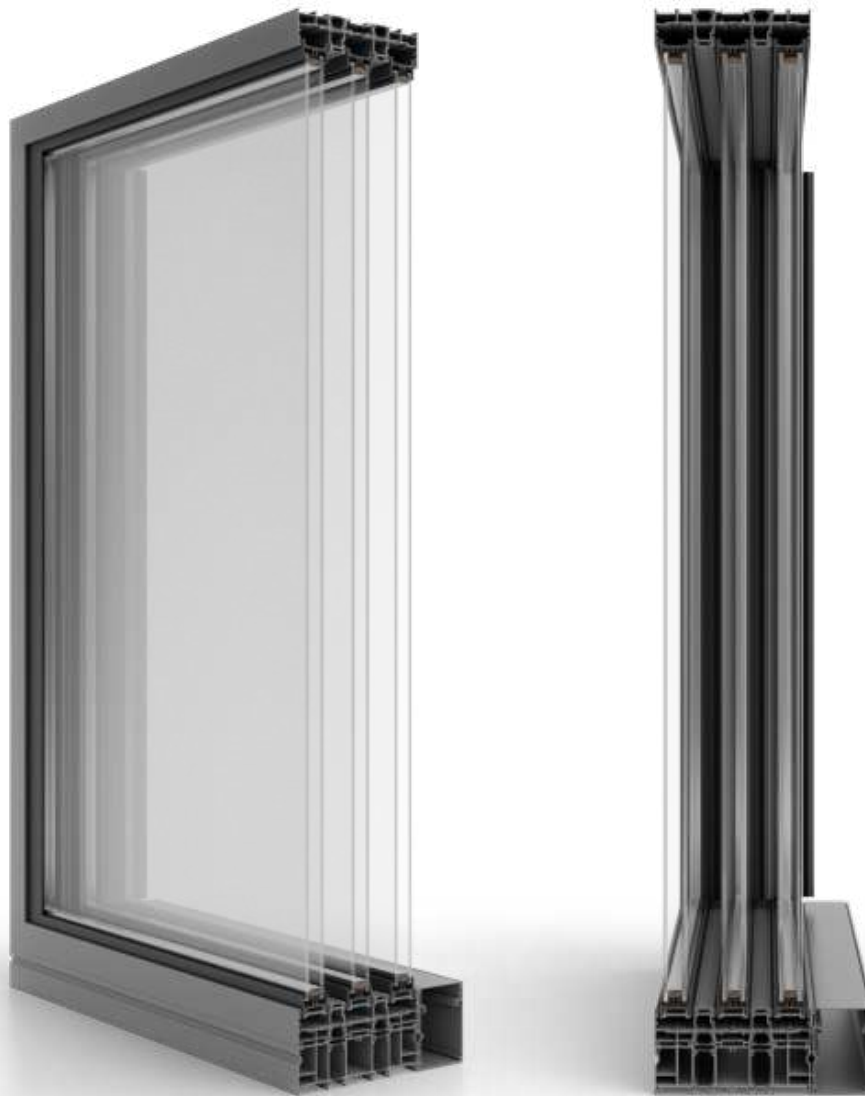

COR Vision GALANDAGE is an innovative solution that allows for the full opening of the door by completely concealing the sashes within the adjacent walls. Depending on the chosen option, one, two, or even three movable sashes can be fully hidden in the wall, leaving an unobstructed space.

TECHNICAL DATA	COR VISION GALANDAGE
Installation depth	115,8 - 181,8 mm
Infill thickness	24 mm
MAXIMUM DIMENSIONS AND WEIGHTS OF THE STRUCTURE	
Max. sash dimensions	H 3000 mm L 2500 mm
Max. sash weight	320 kg

EXTENSION PROFILES

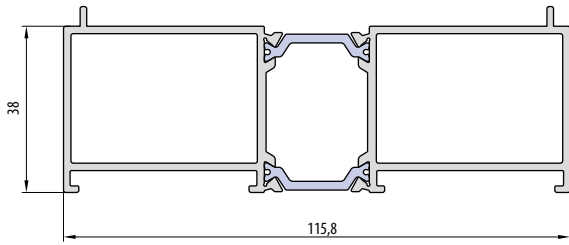

COR-4397

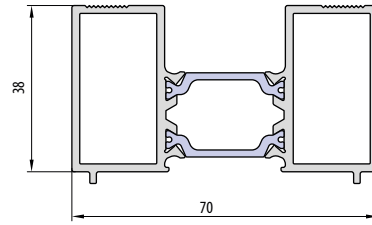

COR-3846

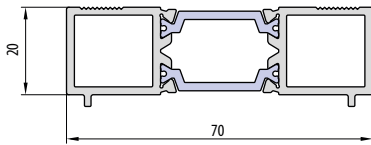

COR-3847

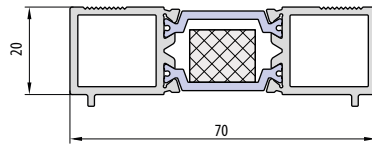

COR-3848

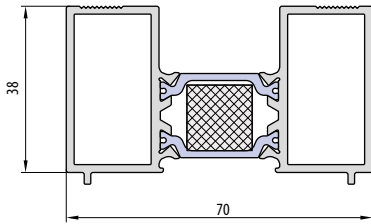

COR-3849

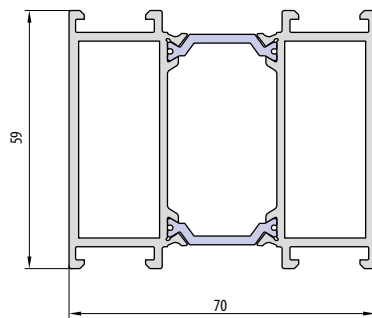

COR-7985

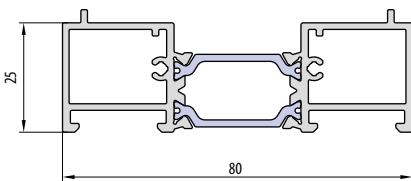

COR-3733

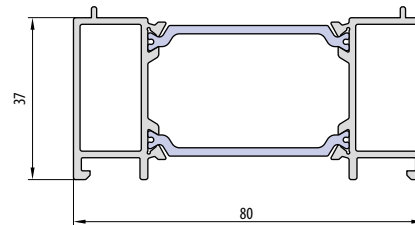

COR-3734

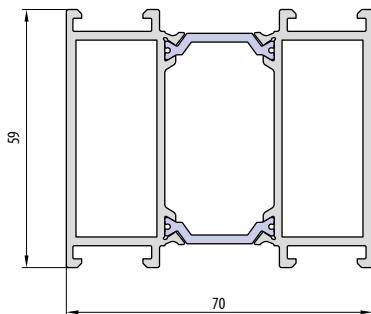

COR-7985

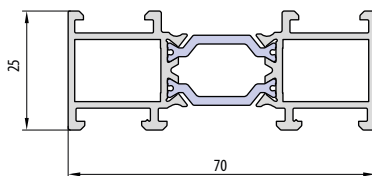

774156



REYNAERS SYSTEMS



MASTERLINE 8	78
MASTERLINE 8 HIDDEN VENT	79
MASTERLINE 8 DESPIRO	80
MASTERLINE 10	81
SLIMLINE 38	82
CS 77	83
SLIMWALL 35	84
MASTERPATIO	85
MASTERLINE 8 PIVOT	86
MASTERLINE 8 PIVOT XL	87
SLIMPATIO 68	88
EXTENSION PROFILES	90



MASTERLINE 8

WINDOW SYSTEM



A combination of very good parameters with functionality and a wide range of solutions. It allows for easy customization to meet client expectations, utilizing Despiro panels and permitting pivot solutions.

TECHNICAL DATA	MASTERLINE 8
Frame depth	77 mm
Sash depth	87 mm
Glazing thickness (fixed window / opening windows)	up to 62 mm
MINIMUM VISIBLE PROFILE WIDTH	
Frame	53 mm
Sash	20 mm (invisible)
MAXIMUM DIMENSIONS AND WEIGHTS OF THE STRUCTURE	
Max. window dimensions	H 2800 mm L 1200 mm
Max. sash weight	200 kg

MASTERLINE 8 HIDDEN VENT

WINDOW SYSTEM



A characteristic feature of the system is the hidden sash. The frame used in it makes the sash profile hidden behind the outer frame profile. This gives the entire facade an aesthetic and coherent look.

TECHNICAL DATA	MASTERLINE 8 HIDDEN VENT
Frame depth	77 mm
Sash depth	77 mm
Glazing thickness (fixed window / opening windows)	up to 65 mm
MINIMUM VISIBLE PROFILE WIDTH	
Frame	53 mm
Sash	20 mm (invisible)
MAXIMUM DIMENSIONS AND WEIGHTS OF THE STRUCTURE	
Max. window dimensions	H 2800 mm L 1200 mm
Max. sash weight	170 kg

MASTERLINE 8 DESPIRO

DOOR SYSTEM

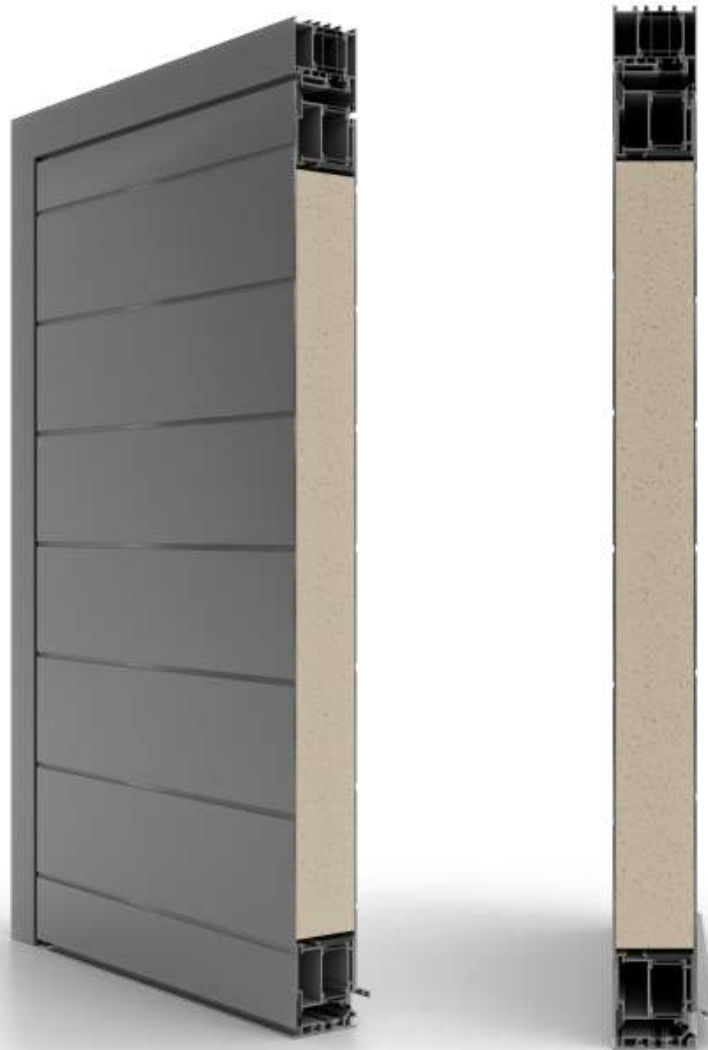

Despiro aluminium doors in the MasterLine 8 system combine reliability with elegant minimalism. Customers can order doors up to three meters high, made from 3-millimeter aluminium sheets, ensuring high resistance to damage.

TECHNICAL DATA	MASTERLINE 8 DESPIRO
Frame depth	77 mm
Sash depth	77 mm
Glazing thickness	67 mm
MAXIMUM DIMENSIONS AND WEIGHTS OF THE STRUCTURE	
Max. door dimensions	H 3000 mm L 1500 mm
Max. sash weight	200 kg

*Despiro is also available in MB86 and Aliplast Genesis.

MASTERLINE 10

WINDOW AND DOOR SYSTEM



The system allows for the creation of doors and windows that meet stringent energy efficiency standards. Its distinguishing feature is the ability to create large glazed areas, including in the most impressive corner solutions.

TECHNICAL DATA	MASTERLINE 10
Frame depth	97 mm
Sash depth	107 mm
Glazing/infill thickness	29 - 88 mm (sash)
VISIBLE PROFILE WIDTH FROM THE OUTSIDE	
Door frame	60 mm
Door sash	37 mm
MAXIMUM DIMENSIONS AND WEIGHTS OF THE STRUCTURE	
Max. door sash dimensions	H 2800 mm L 1200 mm
Max. sash weight	200 kg

SLIMLINE 38

WINDOW SYSTEM

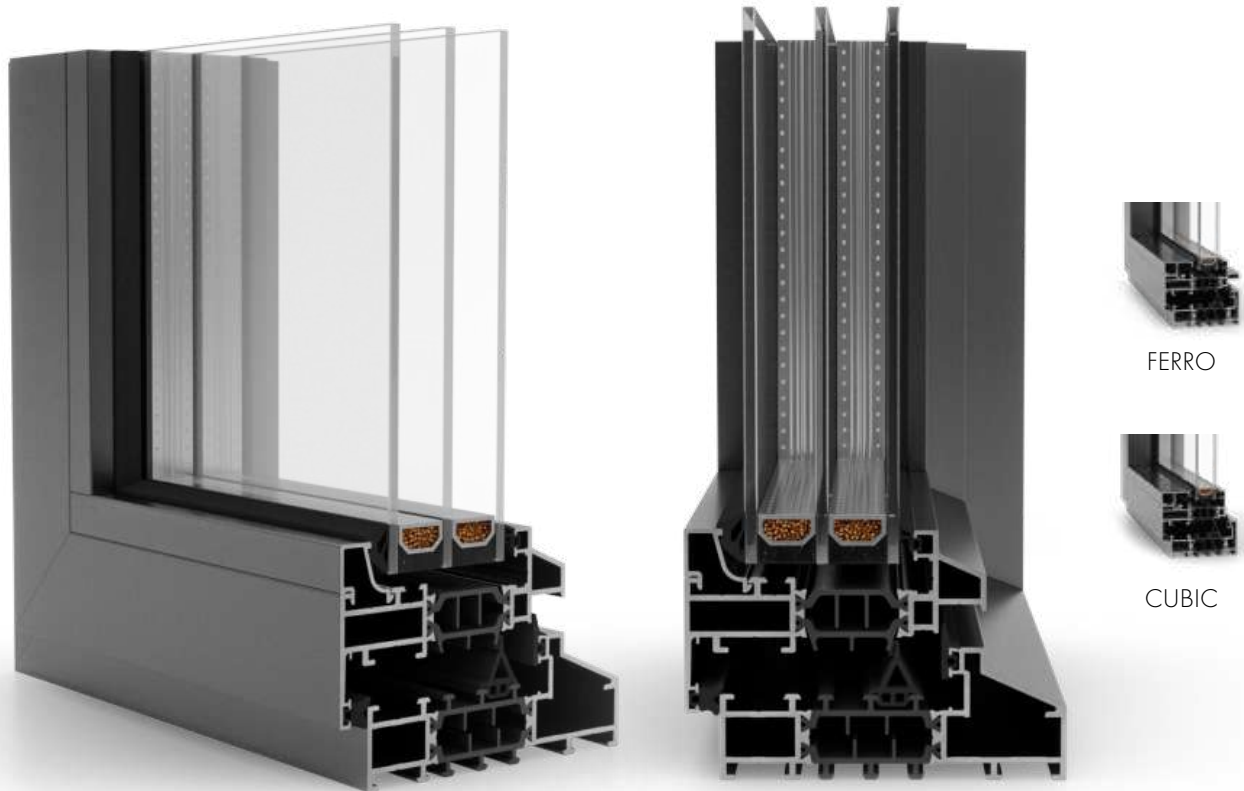

SlimLine 38 are energy-efficient aluminium windows available in three profile versions, referencing the traditional design of steel windows to varying degrees. They are a good choice for new investments and for the renovation of older buildings.

TECHNICAL DATA	SLIM LINE 38
Frame depth depending on version)	76-99 mm
Sash depth	86 mm
Glazing thickness (fixed window / opening windows)	up to 55 mm
MAXIMUM DIMENSIONS AND WEIGHTS OF THE STRUCTURE	
Max. window dimensions	H 1200 mm L 2800 mm
Max. sash weight	170 kg

CS 77

WINDOW AND DOOR SYSTEM



A special thermal break and the option of using triple-glazed units provide excellent thermal and acoustic insulation.

TECHNICAL DATA	CS 77
Frame depth	68 mm
Sash depth	77 mm
Glazing/infill thickness	4 -52 mm (fixed glazing and doors), 63 mm (window sash)
VISIBLE PROFILE WIDTH FROM THE OUTSIDE	
Door frame / wall frame	51 mm
Door sash / wall sash	60 mm
MAXIMUM DIMENSIONS AND WEIGHTS OF THE STRUCTURE	
Max. sash dimensions	H 2800 mm L 1250 mm
Max. sash weight	170 kg

SLIMWALL 35

FACADE



The Slim Wall 35 facade system was created for energy-efficient buildings, offering impressive curtain walls with thermal parameters that meet the requirements of passive construction. Slim Wall 35 perfectly complements Masterline 8 windows and doors, enabling the realization of unique, minimalist homes with very large glazed areas.

TECHNICAL DATA	SLIMWALL 35
Mullion depth	89 - 194 mm
Glass thickness	24 - 57 mm
VISIBLE WIDTH	
Door frame	60 mm
MAXIMUM DIMENSIONS AND WEIGHTS OF THE STRUCTURE	
Max. glazing weight (opening / fixed)	180 / 450 kg

MASTERPATIO

LIFT-AND-SLIDE DOOR SYSTEM

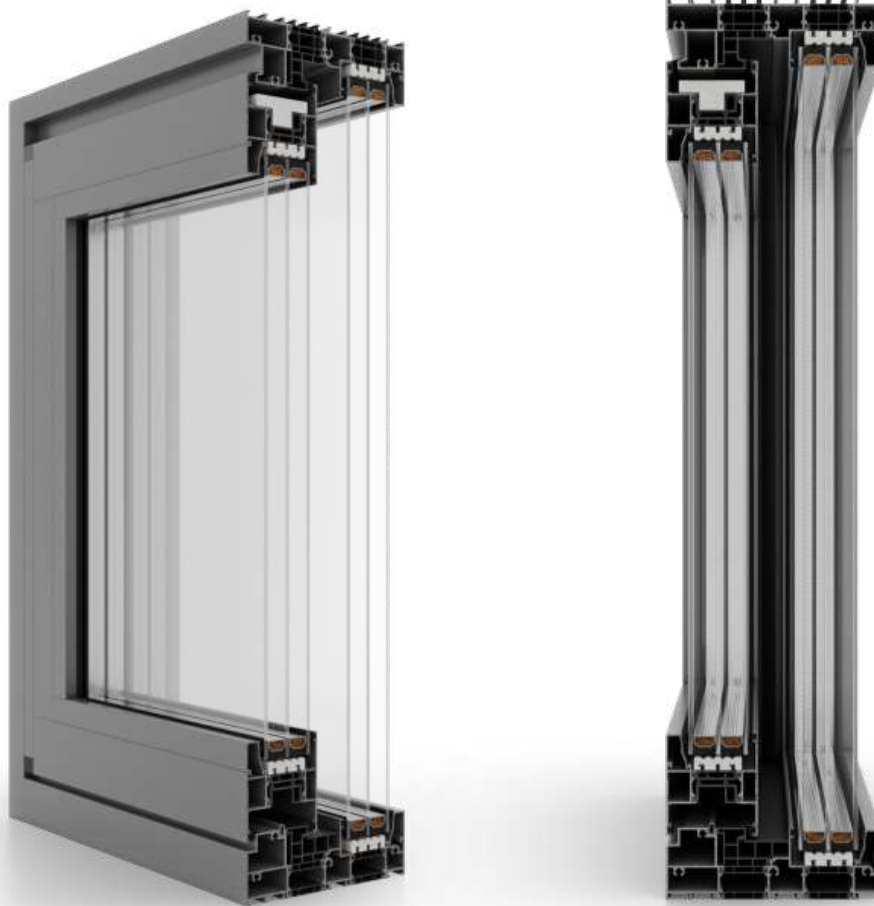

The profiles are almost invisible, constituting only about 10% of the opening's light. The visibility of plastic components and gaskets has been minimized by concealing them within the profiles. At the same time, a heat transfer coefficient suitable for passive buildings has been achieved. In selected variants, a low or flush-with-the-floor threshold can be used. An integrated mosquito net option up to 1 m wide is available.

TECHNICAL DATA	MASTERPATIO
Frame depth	180 mm
Sash depth	77 mm
Glazing thickness (fixed window / opening windows)	up to 62 mm
MAXIMUM DIMENSIONS AND WEIGHTS OF THE STRUCTURE	
Max. window dimensions	H 3500 mm L 2800 mm
Max. sash weight	500 kg

MASTERLINE 8 PIVOT

DOOR SYSTEM



A system that enables the creation of unique pivot door structures, opening either outwards or inwards. The modern appearance of the doors and their exceptional functionality make them suitable for commercial properties and regular homes.

TECHNICAL DATA	MASTERLINE 8 PIVOT
Frame depth	77 mm
Sash depth	77 mm
Glazing thickness	up to 62 mm
MAXIMUM DIMENSIONS AND WEIGHTS OF THE STRUCTURE	
Max. dimensions	H 3000 mm L 1700 mm
Max. sash weight	200 kg

MASTERLINE 8 PIVOT XL

DOOR SYSTEM



With the MasterLine 8 Pivot XL system, it is possible to create huge glazed partitions, consisting of one or even three movable sashes. This is a solution designed for the most impressive private and public spaces, combining futuristic aesthetics with the highest functionality.

TECHNICAL DATA	MASTERLINE 8 PIVOT XL
Frame depth	77 mm
Sash depth	77 mm
Glazing thickness	up to 62 mm
MAXIMUM DIMENSIONS AND WEIGHTS OF THE STRUCTURE	
Max. dimensions	H 4000 mm L 2500 mm
Max. sash weight	500 kg

SLIMPATIO 68

SLIDING SYSTEM



The modern SlimPatio 68 system is distinguished by concealed outer frames, which makes the glazed areas appear even larger. It is available in two sash versions: SV, which emphasizes minimalism, and LV, which allows for the use of double-chamber sealed units.

TECHNICAL DATA	SLIMPATIO 68
Frame depth (2 tracks/3 tracks)	120 mm / 176 mm
Sash depth	37 mm
Glazing thickness (SV / LV)	24 - 30 mm / 32 - 38 mm
MAXIMUM DIMENSIONS AND WEIGHTS OF THE STRUCTURE	
Max. dimensions	H 2700 mm L 2300 mm
Max. sash weight	250 kg



EXTENSION PROFILES

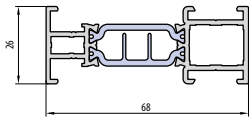

008.3896

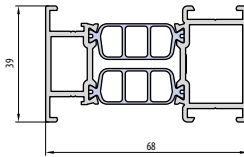

008.3893

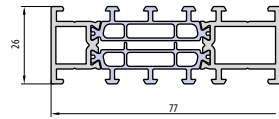

408.0890

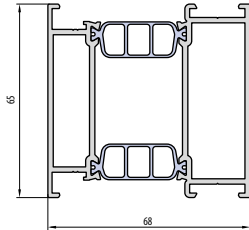

008.3894

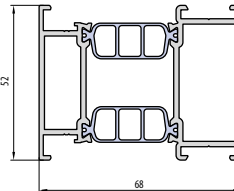

008.3897

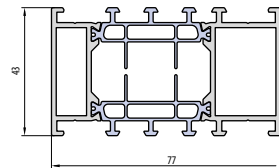

408.0894

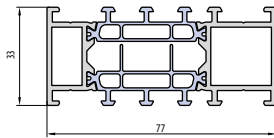

408.0892

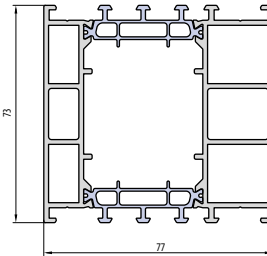

408.1896

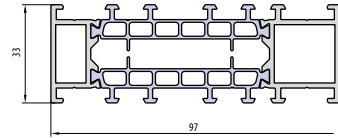

501.1892

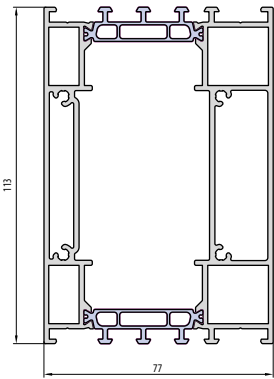

408.1891

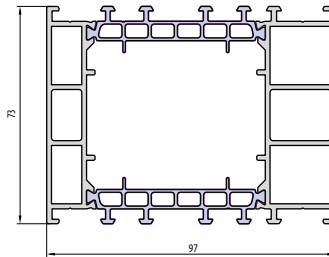

501.2896

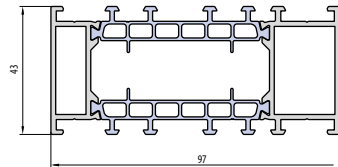

501.1894

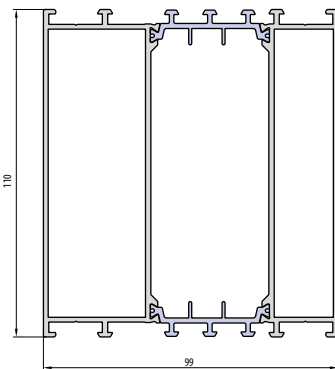

403.0896

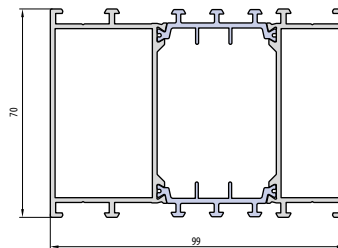

403.0894

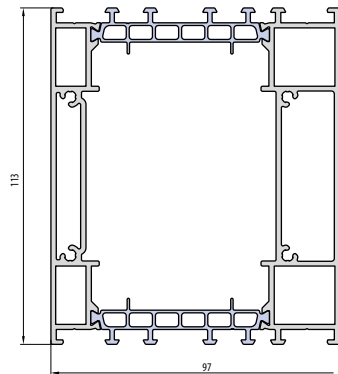

501.2891

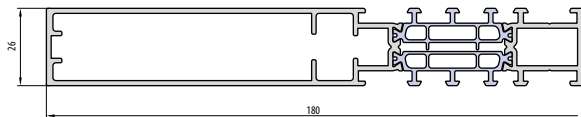

408.0176



COLOUR PALETTE

Aluminium profiles offer immense design possibilities. Their versatility is ensured by lacquering in colours from the RAL K7 palette and lacquers that create wood-effect finishes.



RAL



TIGER



wood-effect finishes

EXCLUSIVE ALULINE

PRODUCT SET

The Exclusive Aluline product line saves a significant amount of time needed to select joinery for the entire house. Above all, it guarantees a cohesive look for windows and doors and the best technical parameters.

COR Vision Plus is a system of large-format sliding doors, designed with large glazed areas in mind. The glass surface can occupy as much as 94% of the entire opening. This allows for maximum filling of interiors with natural light without obstructing the view of the world.

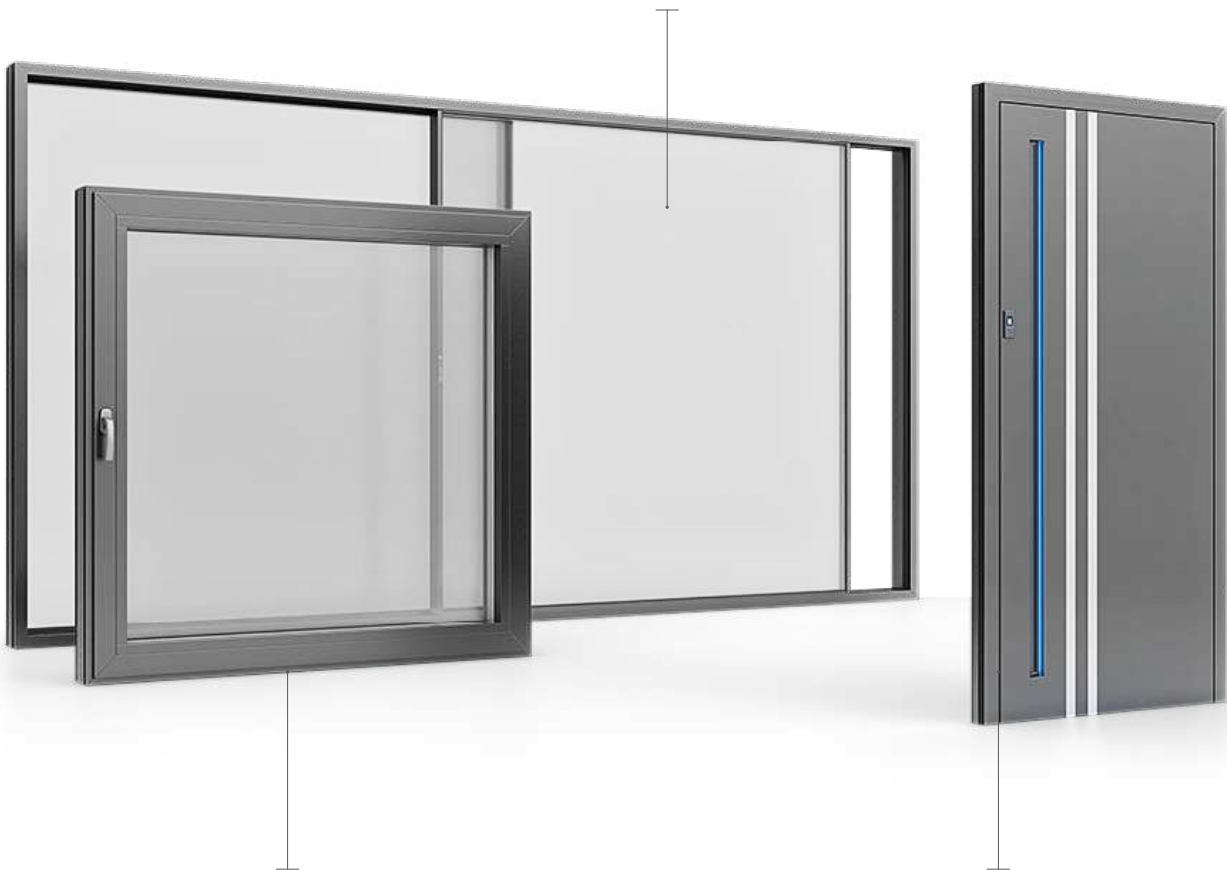

Decalu 88 Hidden is a prestigious window system, distinguished by its hidden sash, which from the outside gives the effect of fixed glazing in the frame. This desirable effect allows for the creation of impressive facades that, thanks to the technologies used, will also offer outstanding acoustic and thermal insulation.

Despiro, an innovative and elegant collection of external doors, offers a large number of designs and colour variants. It is a product refined to the highest level, not only in terms of aesthetics but also reliability, functionality, and durability.

EKO PERSIANE

EXTERNAL SHUTTERS

Eko Persiane aluminium shutters offer a stunning Mediterranean design based on modern technologies and the durability of aluminium. Their appearance is reminiscent of the traditional style of various Italian regions, and their technical parameters allow Eko Persiane to be used even outside the areas that inspired their creation.



ANGELA | AURORA

fixed louvres movable louvres

- Sliding option available (on special order)
- Sashes can be mounted directly to the wall
- Possible to mount on frames with 45 or 62 mm renovation fins



OBSCURA

- Shutter frame is visible only from the inside when the shutter is closed
- Sashes can be mounted directly to the wall
- Possible to mount on frames with 45 or 62 mm renovation fins



SELENE | ITACA

fixed louvres

- Closing with an espagnolette/handle
- Mounting with a frame with a 25 mm renovation fin
- 6 hinge colours matched to the shutter colours



NIKE | ATLANTE

movable louvres

- Closing with an espagnolette/handle
- Mounting with a frame with a 25 mm renovation fin
- 6 hinge colours matched to the shutter colours



CORTIZO TAMIZ

EXTERNAL SHUTTERS

Aluminium external shutters are a modern product that harks back to traditional styling. These facade-mounted window covers offer excellent functionality, allowing you to control the amount of light and heat inside and guaranteeing privacy. At the same time, they are an extraordinary addition to any facade, giving it a unique character.



SHUTTER FEATURES

- Adjustable or fixed-angle louvres
- Lacquered in selected RAL colours and available in selected wood-effect decors
- Modern Roto Fentro hardware

fixed



side-hung

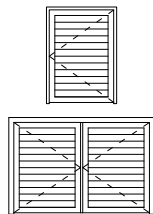

sliding

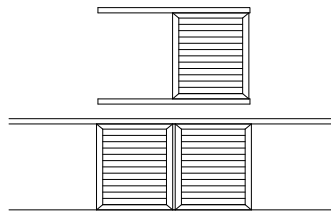

side-hung and folding

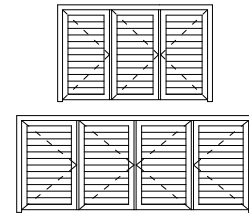

TECHNICAL DATA	TAMIZ
Max. width	1600 mm
Max. height	2500 mm
Max. sash weight	65 kg
Frame depth	47 mm
Sash depth	40 mm



ALULINE

ALUMINIUM DOORS

Aluline panels offer many designs and the possibility of manufacturing doors according to the client's individual project, provided its feasibility is confirmed.



AluLine

Panel Infill

We offer panels with three types of infill - polyurethane foam, plywood, or extruded polystyrene XPS. Each can have a thickness of 24, 36, or 48 mm. The panels, depending on customer preferences and technical requirements, are made from HPL boards or aluminium sheets. HPL boards are veneered, while sheets are lacquered.

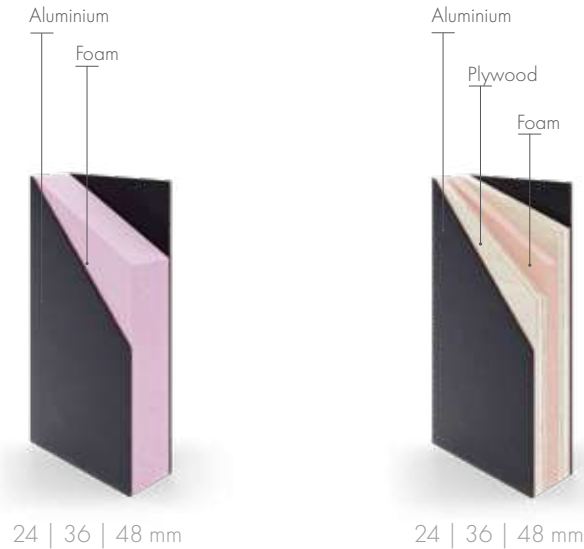

Door glazing

As standard, the glazing in door panels is made of frosted glass. In 24 mm thick panels, we use safety glass on the external side. In 36 and 48 mm thick panels, the glazing is made of safety glass on both sides. Images are for illustrative purposes.



Ornamental glazing

We offer a wide range of glass with motifs, made from transparent glass, as well as ornamental glass in the most popular patterns. Ornamental glass is perfect for homes, offices, shops, hotels, and restaurants. It provides privacy and brightens the interior.



EKOVITRE

GLASS PANELS

EkoVitre is not only about style, but also about safety and high energy efficiency. The panels are constructed from two panes of VSG glass, one of which features sandblasted patterns.



01



02



03



04



05



06



07



08



09



10



11



12



13



14



15

DESPIRO

EXCLUSIVE ALUMINIUM DOORS

1

Aesthetic decorative panels available in many different patterns and colours from the RAL palette, as well as wood-effect finishes.

2

Solutions available with or without a threshold.

3

Gaskets ensuring high water and air tightness, which affects user comfort and savings.

4

Four construction variants: ST, SI, SI+, and AERO, allowing for very good thermal parameters.

5

Rigid and durable aluminium profiles allowing for the production of large-sized doors.

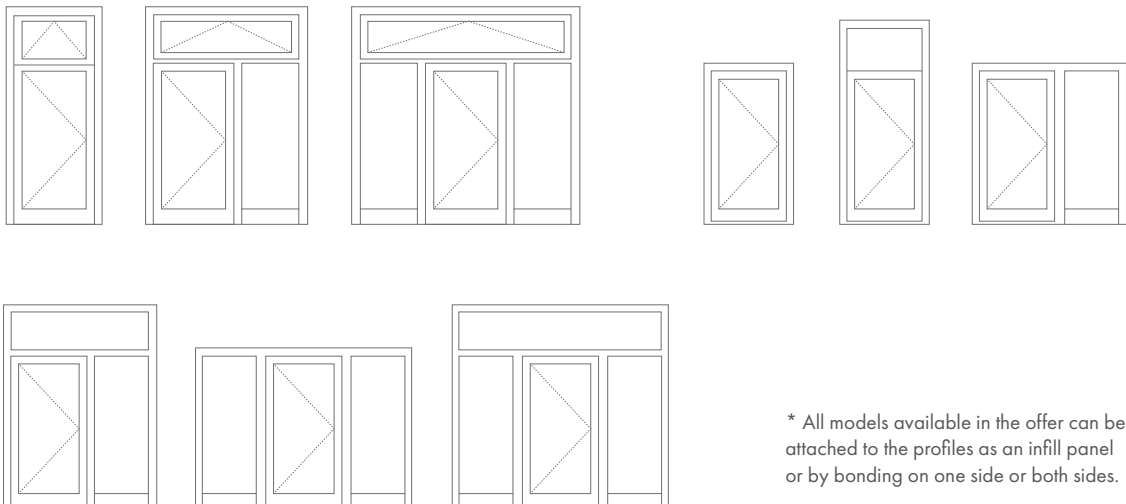

* All models available in the offer can be attached to the profiles as an infill panel or by bonding on one side or both sides.



RETRO LINE

DESPIRO ALUMINIUM DOORS

The Despiro Retro Line panels feature timeless designs with decorative details in a classic style. They are a perfect match for any elegant facade. The door models in this line combine traditional aesthetics with modern technology.



RL01



RL02



RL03



RL04



RL05



RL06



RL07



RL08



RL09



PIVOT LINE

ALUMINIUM PIVOT DOORS

The PIVOT collection features modern door infills that stand out with their unique design and offset pivot axis, fitting perfectly into contemporary architecture. 15 new models combine aesthetics with technology to create a stylish solution for PIVOT door systems.





PIVOT 01

LED lighting in colours:

cool white | warm white

Material: Aluminium

Colour: RAL 7016

Handle: PWZ integrated with the panel in the
infill colour RAL 7016, L-2200 mm

Escutcheon: RS 20 black



PIVOT 02

LED lighting in colours:

cool white | warm white

Material: Aluminium

Colour: RAL DB 703 structure

Application: Milling

Handle: PWZ 2022 PIVOT
colour RAL DB 703,
STRUCTURE, L-2000 mm

Escutcheon: RS 20 black



PIVOT 03

LED lighting in colours:

cool white | warm white

Material:	Aluminium
Colour:	RAL 7021
Handle:	PQ WE 26 colour RAL 9005, dimensions: 40x20 mm, L-2000 mm
Escutcheon:	RS 20 black



PIVOT 04

LED lighting in colours:

cool white | warm white

Material:	Aluminium
Colour:	RAL DB 703 structure
Handle:	PZL matched to the panel height in 9005, L-3000 mm
Escutcheon:	RS 20 black



PIVOT 05

LED lighting in colours:

cool white | warm white

Material:	Aluminium
Colour:	RAL 9007
Application:	Milling
Handle:	PWZ
Escutcheon:	RS 20 black RAL 9007



PIVOT 06

LED lighting in colours:

cool white | warm white

Material:	Aluminium Quartz sinter
Colour:	RAL 9005 Ossido Bruno
Application:	Black 6 x 6 mm
Handle:	PS 10 CD colour RAL 9005, L-1200 mm
Escutcheon:	Stick-on, black



PIVOT 07

LED lighting in colours:
cool white | warm white

Material:	Aluminium
Colour:	RAL 9005 Woodec Alpine
Application:	Flush-mounted 9005
Handle:	PZW colour RAL 9005, L-800 mm
Escutcheon:	RS 20 black



PIVOT 08

LED lighting in colours:
cool white | warm white

Material:	Aluminium
Colour:	RAL 9005 with 3D slats
Application:	Vertical 3D slat in Winchester colour
Handle:	PZY L – 3000 mm integrated with the panel in RAL 9005
Escutcheon:	RS 20 black



PIVOT 09

LED lighting in colours:

cool white | warm white

Material:	Aluminium
Colour:	black
Handle:	PWZ colour RAL 9005, L-2200 mm
Escutcheon:	61421 black
Plate:	Stick-on, black



PIVOT 10

LED lighting in colours:

cool white | warm white

Material:	Quartz sinter
Colour:	ABU DHABI WHITE
Handle:	PS 10 gold
Escutcheon:	RS 20 gold
Plate:	Stick-on, gold



PIVOT 10 PWZ

LED lighting in colours:

cool white | warm white

Material:	Quartz sinter
Colour:	ABU DHABI WHITE
Handle:	PWZ colour RAL 9016, L-2200 mm
Escutcheon:	RS 20 white
Plate:	Stick-on, white



PIVOT 11

LED lighting in colours:

cool white | warm white

Material:	Aluminium
Colour:	lacquer Decoral Natural oak
Application:	Black 6 x 6 mm
Handle:	PWZ 2022 colour RAL 9005, L- 500 mm
Escutcheon:	RS 20 black





PIVOT 12

LED lighting in colours:

cool white | warm white

Material:	Aluminium
Colour:	black
Handle:	PWZ colour RAL 9005, L-2200 mm
Escutcheon:	61421 black
Plate:	Stick-on, black



PIVOT 13

LED lighting in colours:

cool white | warm white

Material:	Quartz sinter
Colour:	ABU DHABI WHITE
Handle:	PS 10 gold
Escutcheon:	RS 20 gold
Plate:	Stick-on, gold



PIVOT 14

LED lighting in colours:

cool white | warm white

Material:	Aluminium
Colour:	RAL 7016
Application:	Milling
Glass:	Satinova
Handle:	PQ 10 tainless steel, dimensions 40x20 mm, L-2200 mm
Escutcheon:	RS 20 colour RAL 7016



PIVOT 15

LED lighting in colours:

cool white | warm white

Material:	Aluminium
Colour:	VIP Rustico
Application:	Milling, vertical and horizontal application colour VIP Amber
Handle:	PZL matched to the panel height colour 9005, L-3000 mm
Escutcheon:	RS 20 black

NUUN ECO

BIOCLIMATIC PERGOLA

A pergola is a luxurious decorative element and an additional space for spending time outdoors, regardless of the weather conditions. The structure consists of a stable aluminium frame and an opening roof, which allows you to regulate the amount of light.



TECHNICAL FEATURES & ACCESSORIES

- Adjustable louvres with integrated LED lighting
- Perimeter LED lighting built into the structure
- Weather station: rain, temperature, and wind sensors
- Durable extruded aluminium construction
- Powder coating in any RAL colour
- Automated control systems

TECHNICAL DATA	NUUN ECO
Width	1,2 m - 4 m
Height	2,2 m - 3 m
Maximum projection	0,8 m



SELT SB350

BIOCLIMATIC PERGOLA

The Selt SB350 freestanding aluminium pergola allows you to create a comfortable space with an adjustable roof for relaxation and gatherings with family and friends. The ability to remotely rotate the louvres means that users can enjoy exactly the amount of sun that suits them.



PERGOLA EQUIPMENT

- post profile 130 x 130 mm
- louvre spacing 150 mm
- drainage to all posts (possibility of blocking one outlet per gutter)
- maximum roof snow load 30 kg/m²
- motor type 24V DC (230V AC power supply)
- control via a dedicated remote or smartphone (wifi)
- safe operating temperature +5 to +40°C (for moving louvres)

TECHNICAL DATA	SELT SB350
Fixed width	3,5 m
Fixed height	2,665 m
Projection	3,40 / 3,85 / 4,30 / 4,75 m



RESIDENTIAL FENCING

Residential fencing solutions combine functionality with aesthetics. Profiles made of aluminium are highly resistant to weather conditions, biological factors, and mechanical damage. The fences feature universal span designs, making them compatible with both modern and more traditional arrangements. Furthermore, it is possible to integrate them with smart home systems.



TECHNICAL DATA	SLIDING GATES
Gates	5200 mm x 2000 mm*
TECHNICAL DATA	DOUBLE-LEAF GATES
Gates	5000 x 2000 mm*
Wickets	Min. width 900 mm Max. height 2000 mm
Spans	Max. dimension 2500 mm x 2000 mm

*Some fence designs require special reinforcement for larger dimensions.
The possibility of making a fence with dimensions exceeding the maximum is determined individually.





PIATTO EK.20.101



LESINA EK.20.102



TRASIMENO EK.20.105



CAMPELLI EK.20.106

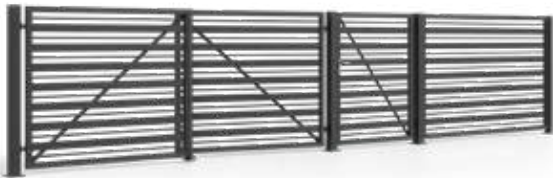

NEMI EK.20.107



MAULAZZO EK.20.108



MAGGIORE EK.20.109



BRACCIANO EK.20.110



VIVERONE EK.20.111



AVERNO EK.20.112

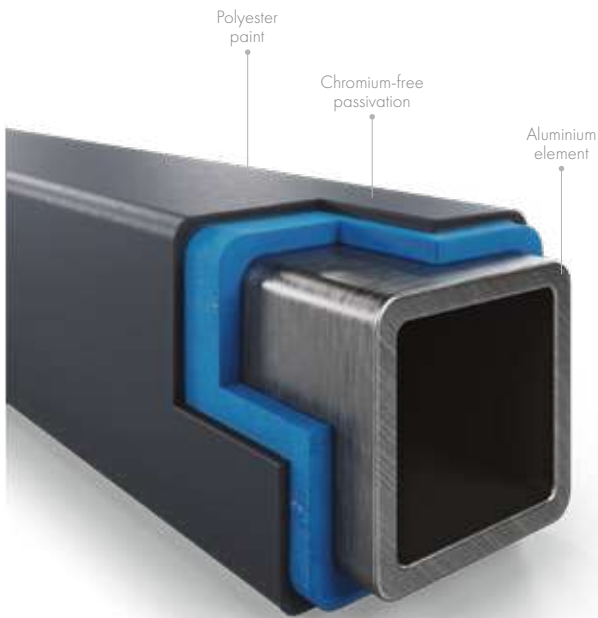

Fence Colours

Aluminium fences can be painted in all colours from the RAL palette. This allows the fence elements to be perfectly matched to the visual aesthetics of the property. Using the RAL palette guarantees that the final effect will precisely meet the client's expectations.

It is also possible to achieve matt or textured finishes, depending on the selected option.

The highest class of material guarantees quality.

Fencing accessories

drive for sliding gates



drive for swing gates



signal lamp



LED lighting



multimedia post



letterbox



handles and pullhandles



video intercom





Scan
the code

eko4u.com

eko 4u

eko4u is a tool for distributors in the joinery industry. eko4u represents a new dimension in managing your business. With it, you can:



- create offers and orders independently
- control deliveries
- browse and download invoices
- submit complaints



benefit Eko-Okna is a free, industry-specific compendium of knowledge about joinery.

It contains everything that is needed in the daily work of a distributor:



- product tutorial
- technical catalogue
- garage doors calculator
- materials from suppliers
- materiały marketingowe



benefit.ekookna.com